



Assembly Instructions

Plant Inn Compact - Clear Glazing

Approx. Dim.

118Lx62.5Wx146.5Hcm / 46.4"Lx24.6"Wx57.7"H

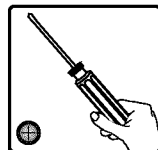
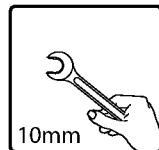
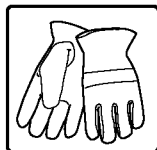
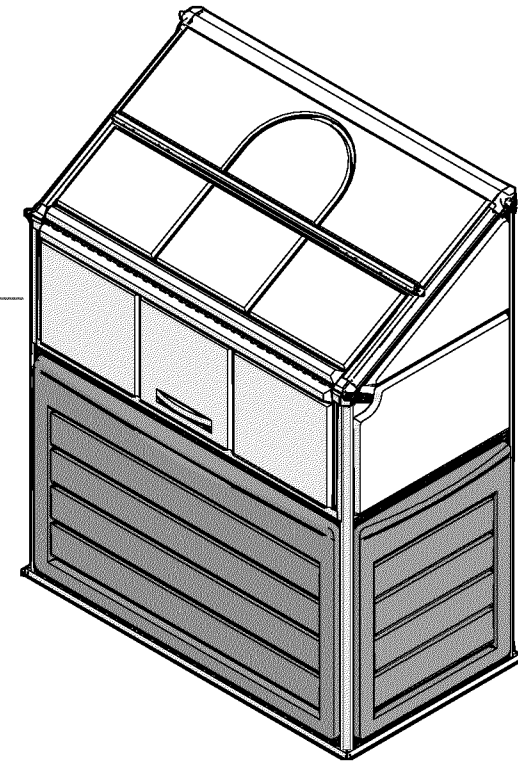

After Sale Service

Email: customer.service@palram.com

USA 877-627-8476
Canada 1 800-866-5749

England 01302-380775
Germany 0180-522-8778

France 0169-791-094
International +972 4-848-6942

www.palramapplications.com

IMPORTANT

Please read these instructions carefully before you start to assemble this product.
Keep these instructions in a safe place for future reference.

⇒ **Customer Service**

For assistance with assembly, replacement parts or any other additional information please log onto our website or call our customer service line (number is on the title page).
www.palramapplications.com

⇒ **Safety advice**

- It is of utmost importance to assemble all of the parts according to the directions. Do not skip any step.
- We strongly recommend using work gloves during assembly.
- Always wear shoes and safety goggles when working with extruded aluminium.
- If using a step ladder or power tools ensure that you follow the manufacturer's safety advice.
- Do not touch overhead power cables with the aluminium profiles.
- Do not attempt to assemble the product in windy or wet conditions.
- Dispose of all plastic bags safely keep them out of reach of small children.
- Keep children away from the assembly area.
- Do not lean against or push the product during construction.
- Do not position your product in an area exposed to excessive wind.
- Do not attempt to assemble this product if you are tired, have taken drugs or alcohol or if you are prone to dizzy spell.
- From safety reasons always use the lockers for each position (close, open, ventilation, storage) as shown in step 33 Hot items such as recently used grills, blowtorches etc. must not be stored in the product. Ensure there are no hidden pipes or cables in the ground before inserting the pegs.
- This product is designed to use as greenhouse only.

⇒ **Care & Maintenance**

When your product needs to be cleaned, use a mild detergent solution and rinse with cold clean water. DO NOT use acetone, abrasive cleaners or other special detergents to clean the clear panels.

⇒ **Tools & Equipment**

- Tape measure
- Work gloves
- Lubricant
- Phillips head screwdriver
- Step ladder
- Drill bit
- Large hammer
- Spanner

- T001 - Special tool for Screws 411 and nuts 412



- Silicon spray

⇒ **Before Assembly**

This is a multi-part assembly best achieved by two people. Allow at least half a day for assembly process.

Selecting a site - the product must be assembled, positioned and fixed on a flat level surface.

Choose a sunny position away from overhanging trees.

Take out all components parts of the packages. Sort the parts and check against the contents parts list.

During assembly parts should be laid out close at hand. Keep all small parts (screws etc.) in a bowl so they do not get lost.

⇒ **Notice**

Step 6 – Make sure screws stay loose.

Step 7 – Make sure screws are strongly tightened.

Step 8 – If trays are dropping down when filled with soil, push trays' frame up and tight these screws again on their original position.

Step 27+28 – make sure profiles are inserted all the way till the end into plastic connector.

Steps 32 – If lid does not located correctly on the frame it will not closed and opened properly.

Try re-checking **step 20** (measure) and **step 27+28** (insert profiles all the way).

For easy inserting of profile 960 use lubricant material or move lid up and down. Do not use hammer.

Tighten all screws when completing assembly.

⇒ **After assembly**

This product's ground fixing is based on soil weight. When trays are empty it should be kept from winds. There for we are strongly recommending fixing the product directly to a solid concrete foundation.

WICHTIG

Bitte lesen Sie diese Anweisungen sorgfältig, bevor Sie mit dem Aufbau des Produktes beginnen. Heben Sie diese Anweisungen an einem sicheren Ort auf, um später auf sie zurückgreifen zu können.

⇒ **Kundendienst**

Für Hilfe bei dem Aufbau oder für Ersatzteile - Können Sie sich entweder auf unserer Webseite einloggen oder unseren Kundendienst anrufen (Die Nummer steht auf der Titelseite)
Weitere Informationen finden Sie auf unserer Webseite: www.palramapplications.com

⇒ **Sicherheitshinweise**

- Es ist von größter Wichtigkeit, alle Teile genau gemäß den Anweisungen zusammenzubauen. Lassen Sie keine Schritte aus.
- Wir empfehlen wärmstens, während des Aufbaus Arbeitshandschuhe zu tragen.
- Tragen Sie immer Schuhe und eine Schutzbrille, wenn Sie mit stranggepresstem Aluminium arbeiten.
- Wenn Sie eine Stufenleiter oder Elektrowerkzeuge benutzen, achten Sie darauf die Sicherheitsanweisungen des Herstellers zu befolgen.
- Berühren Sie mit den Aluminiumprofilen keine Oberleitungen.
- Versuchen Sie nicht das Produkt bei windigem oder regnerischem Wetter zusammenzubauen.
- Entsorgen Sie alle Plastiktüten sicher und bewahren Sie sie außerhalb der Reichweite von kleinen Kindern auf.
- Halten Sie Kinder vom Aufbaubereich fern.
- Während des Aufbaus sollten Sie sich nicht gegen das Produkt lehnen oder es drücken.
- Bauen Sie das Produkt nicht an Orten mit hoher Windbelastung auf.
- Versuchen Sie nicht dieses Produkt aufzubauen wenn Sie müde sind, unter dem Einfluss von Drogen oder Alkohol stehen, oder zu Schwindelanfällen neigen.
- Wegen Sicherheitsgründen immer die Schließfächer für jede Position (Geschlossen, offen, Belüftung, Lagerung) wie in Schritt 33 gezeigt wird benutzen.
- Heiße Geräte wie kürzlich benutzte Grills, Schneidbrenner usw. dürfen nicht in das Produkt gelagert werden.
- Vergewissern Sie sich vor Einsetzen der Pflöcke, dass sich keine versteckten Rohre oder Kabel im Boden befinden.
- Dieses Produkt ist nur für den Einsatz als Gewächshaus geeignet.

⇒ **Sicherheitshinweise**

• When your product needs to be cleaned, use a mild detergent solution and rinse with cold clean water. DO NOT use acetone, abrasive cleaners or other special detergents to clean the clear panels.

⇒ **Pflege u. Wartung**

- Maßband
- Schmiermittel
- Kreuzschlitzschraubendreher
- Stufenleiter
- Bohrer
- Großer Hammer
- Schraubenschlüssel

- T001 - Spezialwerkzeug für Schrauben 411 und Muttern 412



- Silikon Spray

⇒ **Vor der Montage**

Der Zusammenbau der Teile wird am besten von zwei Leuten bewältigt.

Rechnen Sie mit mindestens einem halben Tag für den Zusammenbau.

Wahl des Standorts – Das Produkt muss auf einem flachen, ebenen Untergrund aufgebaut und fixiert werden.

Wählen Sie eine sonnige Stelle abseits überhängender Bäume.

Nehmen Sie alle Teile aus der Verpackung. Sortieren Sie die Teile und überprüfen Sie sie mit Hilfe der Inhaltsliste auf Vollständigkeit.

Während des Aufbaus sollten die Teile in Ihrer Nähe auf dem Boden ausgelegt werden.

Bewahren Sie alle kleinen Teile (Schrauben usw.) in einer Schüssel auf, so dass sie nicht verloren gehen.

⇒ **Ankündigung**

Schritt 6 – Achten Sie darauf, dass die Schrauben locker bleiben.

Schritt 7 - Vergewissern Sie sich, dass die Schrauben fest angezogen sind.

Schritt 8 – Sollten die Ablagekasten wenn Sie mit der Erde gefüllt sind, runterfallen, schieben Sie den Kastenrahmen hoch und ziehen Sie die Schrauben wieder zu an ihre ursprüngliche Position.

Schritt 27-28 - stellen Sie sicher, dass die Profile bis ans Ende in den Kunststoffverbindungsstücken eingesetzt sind.

Schritt 32 – Falls der Deckel nicht richtig auf dem Rahmen positioniert wird, wird der nicht richtig geschlossen und geöffnet werden können. Prüfen Sie erneut

Schritt 20 (messen) und **Schritt 27 +28** (Profile bis ans Ende einführen).

Um Profil 960 einfacher einfügen zu können, verwenden Sie Schmiermittel oder verschieben Sie den Deckel nach oben und unten. Verwenden Sie keinen Hammer.

Alle Schrauben befestigen nach dem Abschluss der Montage

⇒ **Nach der Montage**

Die Bodenbefestigung des Produktes ist auf das Erdegewicht dessen Inhalts bezogen. Wenn die Fächer leer sind, sollte das Produkt vor Wind geschützt werden. Daher geben wir die nachdrückliche Empfehlung das Produkt direkt auf einem massiven Betonfundament zu fixieren.

IMPORTANT!

Veillez lire attentivement ces instructions avant de commencer à assembler votre mini-serre. Conservez ces instructions en lieu sûr pour toute consultation ultérieure.

⇒ **Service clients**

Pour toute assistance concernant le montage de votre mini-serre ou ses pièces de rechange – veuillez consulter notre site Internet ou appeler notre service technique (dont le numéro de téléphone figure sur la page de garde de la brochure).

Pour en savoir plus, n'hésitez pas à visiter notre site Internet : www.palramapplications.com

⇒ **Consignes de sécurité**

- Très important ! Veuillez suivre scrupuleusement les instructions de cette brochure et réaliser les étapes dans l'ordre énoncé, sans exception.
- Nous recommandons vivement le port de gants de protection pendant le montage.
- Portez toujours des chaussures de travail et des lunettes de protection lorsque vous travaillez des pièces en aluminium extrudé.
- Lors de l'utilisation d'une échelle ou d'outils électriques, assurez-vous de bien suivre les consignes de sécurité du fabricant.
- Veillez à ne pas toucher de câbles aériens avec les profilés en aluminium.
- N'essayez pas d'assembler la mini-serre s'il y a du vent ou s'il fait humide.
- Jetez tous les sacs en plastique en appliquant les règles de sécurité et maintenez-les hors de portée des jeunes enfants.
- Eloignez les enfants de la zone d'assemblage.
- Ne vous appuyez pas contre la mini-serre et ne la poussez pas pendant l'assemblage.
- Ne positionnez pas la mini-serre dans un endroit trop exposé au vent.
- N'essayez pas d'assembler ce produit si vous êtes fatigué, si vous êtes sous l'effet de médicaments ou d'alcool ou encore si vous êtes sujet aux vertiges.
- Pour des raisons de sécurité, vérifiez toujours le fonctionnement des pièces mobiles dans toutes les positions (ouvertes, fermées, en position de ventilation, en position de rangement) comme indiqué à l'étape 33.
- Les objets chauds tels qu'un barbecue, un chalumeau ou autre article de ce type ayant été récemment utilisés, ne doivent pas être rangés dans la mini-serre.
- Avant de planter les piquets, assurez-vous qu'aucun tuyau ni câble n'est enterré à l'endroit sélectionné pour l'installation.
- Ce produit est conçu pour servir de bac de culture exclusivement.

⇒ **Entretien & Maintenance**

Pour nettoyer votre mini-serre, utilisez une solution détergente douce et à rincez à l'eau claire et froide. NE PAS utiliser d'acétone ni de produits nettoyants ou autres détergents spéciaux pour nettoyer les panneaux clairs.

⇒ **Outils & Equipement**

- Mètre (ruban)
- Gants de travail
- Lubrifiant
- Tournevis cruciforme (Philips)
- Escabeau
- Perceuse
- Grand marteau
- Clé à écrous

- T001 – outil spécial pour vis 411 et écrous 412

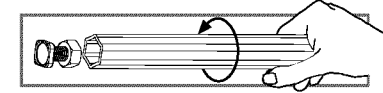

- Pulvérisation de silicium

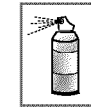
⇒ **Avant l'assemblage**

Il s'agit d'un assemblage à pièces multiples qu'il est préférable de réaliser à deux personnes et auquel il faut consacrer au moins une demi-journée.

Sélection du site – la mini-serre doit être assemblée et fixée sur une surface plane.

Choisissez un emplacement ensoleillé et éloigné d'éventuels arbres susceptibles de la surplomber.

Nous recommandons vivement de fixer le produit directement sur des fondations solides, en béton. Pour ce faire, utilisez les trous déjà percés dans le châssis métallique fourni.

Sortez toutes les pièces de leur emballage. Triez-les et comparez-les avec la liste des pièces pour vérifier que tout y est.

Lors de l'assemblage, les pièces doivent être disposées à portée de main. Gardez toutes les petites pièces (vis, etc.) dans un récipient pour éviter de les perdre.

⇒ **Instructions de montage**

Etape 6 – Assurez-vous que les vis restent relâchées.

Etape 7 – Assurez-vous que les vis soient bien serrées.

Etape 8 – S'il arrive que des bacs tombent lorsque vous les remplissez de terre, poussez le châssis vers le haut et resserrez les vis correspondantes dans leur position d'origine.

Etape 27-28 - assurez-vous que les profilés sont bien insérés sur toute leur longueur et jusqu'au raccord en plastique.

Etape 32 – si le couvercle n'adhère pas au châssis, son ouverture et sa fermeture ne pourront pas se faire correctement.

Etape 20 – Dans ce cas, vérifiez que l'étape **20** (mesures) et l'étape **27+28** (insertion des profilés 960 sur toute la longueur) ont été correctement réalisées.

Serrez toutes les vis après avoir achever l'assemblage.

⇒ **Après l'assemblage**

La base de la mini-serre adhère au sol par l'effet du poids de la terre qu'elle contient. Lorsque les bacs ou les plateaux sont vides, ils doivent être protégés du vent.

IMPORTANTE

Leggi attentamente le istruzioni prima di cominciare a montare il prodotto.

Conserva le istruzioni per riferimento futuro.

⇒ **Servizio Clienti**

Per l'assistenza nel montaggio, per le parti di ricambio e per altre informazioni, entra nel nostro sito web o chiama per telefono il nostro servizio clienti (il numero si trova nella prima pagina).

www.palramapplications.com

⇒ **Consigli sulla sicurezza**

- È di estrema importanza montare tutte le parti secondo le istruzioni. Non saltare nessuna fase.
- Raccomandiamo caldamente di usare guanti da lavoro durante il montaggio.
- Indossa sempre le scarpe e gli occhiali di sicurezza lavorando con alluminio estruso.
- Se usi una scala a libretto o utensili elettrici, assicurati di seguire i consigli del produttore.
- Non toccare cavi elettrici sospesi con i profili di alluminio.
- Non tentare di montare il prodotto quando c'è vento o pioggia.
- Elimina tutte le confezioni di plastica. Tienile lontano dai bambini.
- Allontana i bambini dalla zona di montaggio.
- Non appoggiarti sul prodotto e non spingerlo durante la costruzione.
- Non posizionare il prodotto in una zona esposta a vento eccessivo.
- Non tentare di montare il prodotto se sei stanco, se hai preso medicinali o alcol, o se sei prono alle vertigini.
- Per ragioni di sicurezza usa sempre le chiusure per ogni posizione (chiuso, aperto, ventilazione, stoccaggio) come mostrato nella fase 33. Non si devono riporre nel prodotto oggetti caldi, come griglie usate recentemente, bruciatori per saldare, ecc. Assicurati che non ci siano tubi o cavi nascosti nel terreno, prima di inserire i pioli.
- Questo prodotto è progettato per essere usato solo come serra.

⇒ **Cura e Manutenzione**

Quando il prodotto ha bisogno di essere pulito, usa una soluzione detergente blanda e sciacqua con acqua fredda. NON usare acetone, detergenti abrasivi od altri detergenti speciali per pulire e lucidare i pannelli.

⇒ **Utensili ed Apparecchiatura**

- Metro
- Guanti da lavoro
- Lubrificante
- Cacciavite Phillips
- Scala a libretto
- Trapano
- Martello grande
- Chiave inglese
- T001 – Utensile speciale per le viti 411 e per i dadi 412
- Spray al silicone

⇒ **Prima del montaggio**

Trattandosi di un montaggio con molte parti, è meglio attuarlo in due persone. Il montaggio prende come minimo mezza giornata.

Sceita del sito: il prodotto deve essere montato, posizionato e fissato su una superficie orizzontale piana.

Scegli una posizione al sole, lontana da alberi sovrastanti.

Tira fuori dalle confezioni tutte le parti componenti. Smista le parti e controllale nuovamente, rispetto alla lista delle parti componenti.

Durante il montaggio, bisogna adagiare le parti vicino a portata di mano. Riponi le parti piccole (viti ecc.) in un recipiente, per evitare che vadano perse.

⇒ **Note**

Fase 6 : Assicurati che le viti siano strette bene.

Fase 7 : Verificare le viti sicuro sono fortemente serrati

Fase 8 : Se i recipienti cadono quando sono riempiti di terriccio, tira su l'armatura dei recipienti e stringi le viti di nuovo nella posizione originale.

Fasi 27-28 : Assicurati che i profili siano inseriti fino in fondo nel raccordo di plastica.

Fase 32 : Se il coperchio non è messo correttamente sull'armatura, non si aprirà né chiuderà in modo appropriato.

Controlla di nuovo la **fase 20** (misure) e le **fasi 27+28** (inserimento dei profili fino in fondo).

Per inserire con facilità il profilo 960, usa un materiale lubrificante o muovi il coperchio su e giù. Non usare un martello.

Serrare tutte le viti al momento di compilare il montaggio.

⇒ **Dopo il montaggio**

Il fissaggio del prodotto sul terreno è basato sul peso del terriccio. Quando i recipienti sono vuoti, si deve tenere lontano dal vento.

Per questo, raccomandiamo vivamente di fissare il prodotto direttamente su solide fondamenta di cemento.

IMPORTANTE

Lea por favor estas instrucciones cuidadosamente antes de comenzar a montar este producto. Mantenga estas instrucciones en un lugar seguro para referencia futura.

⇒ **Servicio de Ayuda al Cliente**

Para obtener ayuda con el montaje, con piezas de recambio o cualquier otra información adicional, por favor entre a nuestro sitio web o llame a nuestra línea de servicio al cliente (el número está en la página de título) www.palramapplications.com

⇒ **Consejos de Seguridad**

- Es de suma importancia montar todas las partes de acuerdo con las instrucciones. No salte ningún paso.
- Recomendamos firmemente el uso de guantes del trabajo durante el montaje.
- Use siempre zapatos y anteojos de seguridad al trabajar con aluminio extruido.
- Al usar una escalera plegable o herramientas eléctricas asegúrese de seguir los consejos de seguridad del fabricante.
- No toque los cables eléctricos aéreos con los perfiles de aluminio.
- No intente montar este producto en días de viento o en condiciones de humedad.
- Disponga de todas las bolsas plásticas en lugar seguro - guárdelas fuera del alcance de niños.
- Mantenga a los niños fuera del área de montaje.
- No se apoye ni empuje este producto durante la construcción.
- No coloque su producto en un área expuesta al viento excesivo.
- No procure montar este producto si usted está cansado, ha tomado drogas o alcohol, o si usted es propenso a ataques de mareo.
- Por razones de seguridad utilice siempre los armarios para cada posición (cerrado, abierto, ventilación, almacenaje) como presentado en el paso 33. Artículos calientes recientemente usados tales como parrillas, sopletes etc. no deben ser almacenados en el producto. Asegúrese de que no haya ninguna tubería o cables ocultos en la tierra antes de insertar las clavijas.
- Este producto es designado a ser usado solamente como invernadero.

⇒ **Cuidados & Mantenimiento**

Cuando su producto necesita ser limpiado, utilice una solución detergente suave y enjuague con agua limpia fría. **NO** utilice acetona, limpiadores abrasivos u otros detergentes especiales para limpiar los paneles.

⇒ **Herramientas & Equipo**

- Cinta métrica
- Guantes de trabajo
- Lubricante
- Destornillador cabeza Phillips
- Escalera plegable
- Broca
- Martillo grande
- Llave inglesa

- T001 - Herramienta especial para Tornillos 411 y tuercas 412



- Spray de silicona

⇒ **Antes del Montaje**

Esto es un montaje de varias partes, mejor ejecutado por dos personas.

Dé un plazo de por lo menos medio día para el proceso de montaje.

Seleccionar un sitio – el producto debe ser montado, posicionado y fijo en una superficie plana.

Elija un lugar soleado lejos de árboles con ramas colgantes.

Saque todas las partes componentes de los paquetes. Clasifique las partes y compruebe contra la lista del contenido.

Durante el montaje las partes deben ser colocadas cerca del alcance de la mano. Guarde todas las piezas pequeñas (tornillos etc.) en un tazón para que no se pierdan.

⇒ **Observación**

Paso 6 – Asegúrese de que los tornillos están flojos.

Paso 7 - Asegúrese que los tornillos están firmemente apretados.

Paso 8 – Si las bandejas se caen cuando llenadas con tierra, empuje el marco de las bandejas hacia arriba y apriete estos tornillos otra vez en su posición original.

Pasos 27+28 – cerciórese de que los perfiles estén totalmente insertados hasta el extremo en el conector plástico.

Pasos 32 – Si la tapa no está colocada correctamente en el marco, no se cerrará ni abrirá apropiadamente.

Intente volver a inspeccionar el **paso 20** (medición) y los **pasos 27+28** (insertar los perfiles hasta el final).

Para la fácil inserción del perfil 960 use material lubricante o mueva la tapa hacia arriba y abajo. No utilice martillo.

Apriete todos los tornillos de montaje al completar

⇒ **Después del Montaje**

La fijación en el piso de este producto está basada en el peso del suelo. Cuando las bandejas están vacías deben ser protegidas de los vientos. Por lo tanto, recomendamos firmemente que fije este producto directamente a una fundación de concreto sólido.

BELANGRIJK

Lees deze handleiding a.u.b. zorgvuldig door voordat u begint met de montage van dit product. Bewaar de handleiding op een veilige plaats voor toekomstige raadpleging.

⇒ **Klantenservice**

Voor hulp bij montage, reserveonderdelen of andere vragen kunt u zich aanmelden bij onze website of onze klantenservice bellen (het nummer staat op de titelpagina). www.palramapplications.com

⇒ **Veiligheidsvoorschriften**

- Het is van groot belang dat u alle onderdelen monteert volgens de aanwijzingen in deze handleiding. Sla geen stappen over.
- Wij raden u sterk aan handschoenen te dragen tijdens de montage.
- Draag altijd schoenen en een veiligheidsbril wanneer u met geëxtrudeerd aluminium werkt.
- Als u een ladder of elektrisch gereedschap gebruikt, zorg er dan voor dat u de veiligheidsvoorschriften van de fabrikant opvolgt.
- Zorg ervoor dat u geen overhangende elektriciteitskabels aanraakt met de aluminium profielen.
- Probeer het product niet te monteren wanneer het regent of hard waait.
- Ruim alle plastic zakken meteen op om ze buiten bereik van kleine kinderen te houden.
- Houd kinderen weg van de plaats van montage. • Leun of duw niet tegen het product tijdens de montage.
- Zet het product niet op een plaats die blootgesteld wordt aan harde wind.
- Probeer dit product niet te monteren wanneer u moe bent, drugs of alcohol heeft gebruikt of duizelig bent.
- Gebruik de kastjes om veiligheidsredenen voor elke positie (dicht, open, ventilatie, opslag) altijd alleen zoals getoond in stap 33. Sla geen hitteproducerende artikelen, zoals pasgebruikte barbecues, soldeerbranders etc. op in dit product. Controleer dat er geen leidingen of kabels onder de grond liggen voordat u de pinnen in de grond steekt.
- Dit product is alleen bedoeld voor gebruik als broeikas.

⇒ **Zorg & onderhoud**

Gebruik een oplossing van water en een mild schoonmaakmiddel om dit product te reinigen, en spoel af met koud water. Gebruik GEEN aceton, schuurmiddelen of andere gespecialiseerde reinigingsmiddelen om de doorzichtige panelen schoon te maken.

⇒ **Gereedschap & benodigdheden**

- Meetlint
- Werkhandschoenen
- Smeermiddel
- Kruiskopschroevendraaier
- Ladder
- Boorkop
- Grote hamer
- Moersleutel
- T001 – speciaal gereedschap voor schroeven 411 en moeren 412
- Siliconenspray

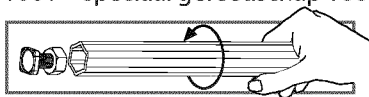
⇒ **Voordat u begint**

Deze montage bevat veel onderdelen en kan het beste door twee mensen uitgevoerd worden.

Trek tenminste een halve dag uit voor het montageproces. Kiezen van de juiste plaats - het product moet op een gelijkmatig oppervlak geplaatst, gemonteerd en bevestigd worden. Kies een zonnige plaats zonder overhangende boomtakken. Haal alle onderdelen uit de verpakking. Sorteert de onderdelen en controleer de inhoudlijst. Houd de onderdelen tijdens de montage binnen handbereik. Bewaar kleine onderdelen (schroeven e.d.) in een bakje, zodat u ze niet kwijt raakt.

⇒ **Opmerkingen**

Stap 6 – Draai de schroeven nog niet vast.

Stap 7 – Draai de schroeven stevig vast.

Stap 8 – Als de bakken naar beneden vallen wanneer ze gevuld worden met aarde, duw het frame van de bakken dan omhoog en draai de schroeven steviger vast in hun originele positie.

Stap 27+28 – duw de profielen helemaal tot aan het eind in de plastic connector.

Stap 32 – Als het deksel niet goed op het frame past, opent en sluit hij niet goed.

Controleer of **stap 20** (meting) en **stap 27+28** (profielen helemaal in de plastic connector duwen) goed uitgevoerd zijn.

Gebruik voor profiel 960 wat smeermiddel of beweeg het deksel op en neer. Gebruik geen hamer.

Draai alle schroeven vast na het voltooiën van de montage.

⇒ **Na de montage**

Dit product wordt op de grond gehouden door het gewicht van de aarde. Wanneer de bakken leeg zijn, moet het product beschermd worden tegen de wind. Daarom raden wij u sterk aan het product aan een betonnen ondergrond te bevestigen.

VIKTIGT

Läs noga igenom dessa instruktioner innan du börjar monteringen av denna produkt. Förvara dessa instruktioner på en säker plats för framtida referenser.

⇒ **Kundtjänst**

För hjälp med montering, reservdelar eller annan information, besök vår hemsida eller ring vår kundtjänst (nummer finns på förstasidan). www.palramapplications.com

⇒ **Säkerhetsanvisningar**

- Det är ytterst viktigt att sätta ihop alla delar enligt anvisningarna. Hoppa inte över något steg.
- Vi rekommenderar starkt att du använder arbetshandskar under monteringen.
- Bär alltid skor och skyddsglasögon när du arbetar med strängpressad aluminium.
- Om du använder en trappstege eller elverktyg, se till att du följer tillverkarens säkerhetsråd.
- Rör inte överliggande elkablar med aluminiumprofilerna.
- Försök inte att sätta ihop produkten i blåsiga eller våta förhållanden.
- Kasserera alla plastpåsar säkert, håll dem utom räckhåll för små barn.
- Håll barn borta från monteringsområdet.
- Luta dig inte mot eller knuffa på produkten under konstruktionen.
- Placera inte produkten i ett område som är utsatt för kraftig vind.
- Försök inte att sätta ihop denna produkt om du är trött, har tagit droger, druckit alkohol eller om du brukar ha yrselattacker.
- Pga säkerhetsskäl, använd alltid låsen för varje position (nära, öppet, ventilation, lagring) såsom visas i steg 33. Heta föremål, såsom nyligen använda grillar, skärbrännare osv. får inte förvaras i produkten. Se till att det inte finns några dolda rör eller kablar i marken innan du sätter in pinnarna.
- Denna produkt är endast avsedd för att användas som växthus.

⇒ **Skötsel och underhåll**

När produkten behöver rengöras, använd ett mildt rengöringsmedel och skölj med kallt, rent vatten. ANVÄND INTE aceton, frätande rengöringsmedel eller andra speciella rengöringsmedel för att rengöra de klara panelerna.

⇒ **Verktyg och utrustning**

- Måttband
- Arbetshandskar
- Smörjmedel
- Skruvmejsel
- Trappstege
- Borr
- Stor hammare
- Skruvnyckel

- T001 – Specialverktyg för skruven 411 och mutter 412



- Silikonspray

⇒ **Före monteringen**

Reservera åtminstone en halv dag för monteringen.

Växthuset skall monteras, placeras och fixeras på ett plant underlag.

Välj ett soligt läge långt bort från överhängande träd.

Ta ut alla komponenter från paketet. Sortera delarna och kontrollera mot innehållsförteckningen.

Vid monteringen bör delarna ligga nära till hands. Håll alla små delar (skruvar osv.) i en skål så att de inte tappas bort.

⇒ **Under monteringen**

Steg 6 : Se till att skruvarna förblir lösa

Steg 7 : Se till att skruvarna är ordentligt åtdragna

Steg 8 : Om brickorna sjunker ner när de är fyllda med jord, tryck upp brickornas ram och dra åt dessa skruvar igen på deras ursprungliga position.

Steg 27+28 : Se till att profilerna är införda till slutet i plastkopplingen

Steg 32 : Om locket inte sitter rätt på ramen kommer det inte att stängas och öppnas ordentligt.

Kontrollera **steg 20** (mätning) och **steg 27+28** (insättning av profiler hela vägen in) en gång till.

För enkel insättning av profilen 960, använd smörjmedel eller flytta locket upp och ner. Använd inte hammare.

Dra åt alla skruvar när du slutför monteringen.

⇒ **Efter monteringen**

Produktens markfäste är baserat på vikten av jorden. När brickorna är tomma bör produkten inte utsättas för vind. Vi rekommenderar därför starkt att fästa produkten direkt till en solid betonggrund.

Contents

Item	Qty.
961	4
7211	2
962	2

956	1
-----	---

958	1
-----	---

957	1
-----	---

960	1
-----	---

Item	Qty.
7018	2
7017	2

7212	1
------	---

7208	2
127	2

7209	2
128	2

Item	Qty.
7213	2

7210	1
------	---

447	10 (+1)
-----	---------

4026	4 (+1)
------	--------

411	56 (+6)
-----	---------

412	56 (+6)
-----	---------

4043	2 (+1)
------	--------

139	2
-----	---

131	4
-----	---

7207	2
------	---

Contents

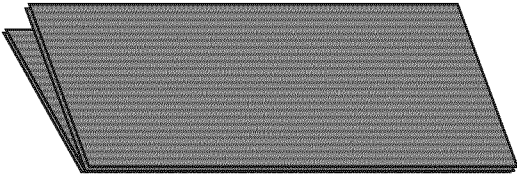
Item	Qty.
7206	1
	

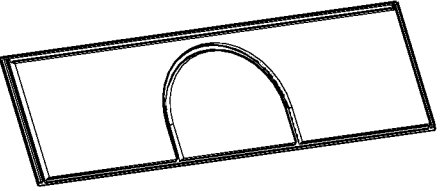
Item	Qty.
295	1
	

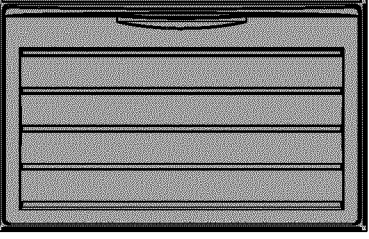
Item	Qty.
298	1
	

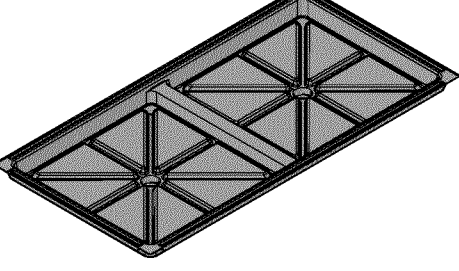
Item	Qty.
299	1
	

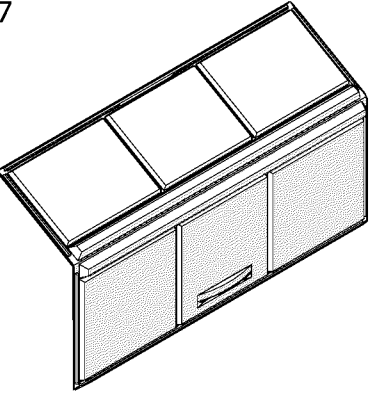
Item	Qty.
297	1
	

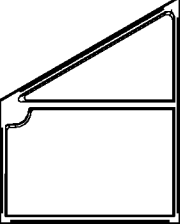
Item	Qty.
7204	1
	

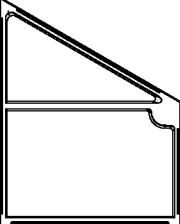
Item	Qty.
7205	1
	

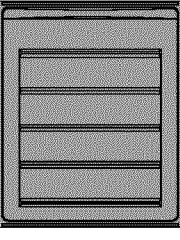
Item	Qty.
7203	2
	

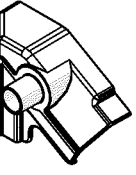
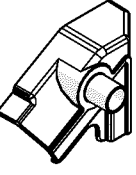

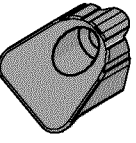
Item	Qty.
7202 Left	1
	
7202 Right	1
	

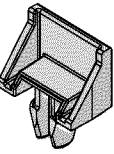
Item	Qty.
301	2
	

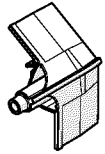
Item	Qty.
328	2 (+1)
	

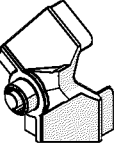
Item	Qty.
7019	2
	

Item	Qty.
302	2
	

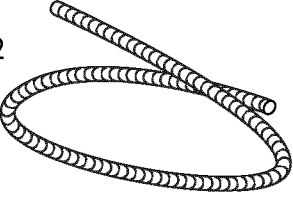

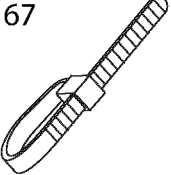
Item	Qty.
69	2
	
68	2
	
7122	2
	

Item	Qty.
67	2
	

Item	Qty.
70	10
	

Item	Qty.
T001	1
	

Item	Qty.
291	2
	

Item	Qty.
318	1
	
	

1

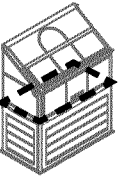

127

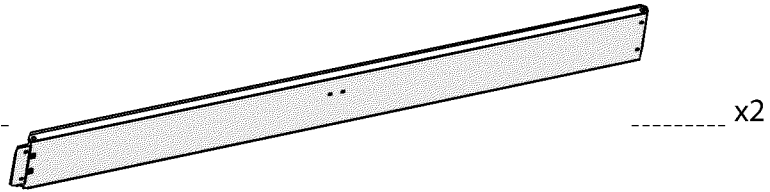

7208

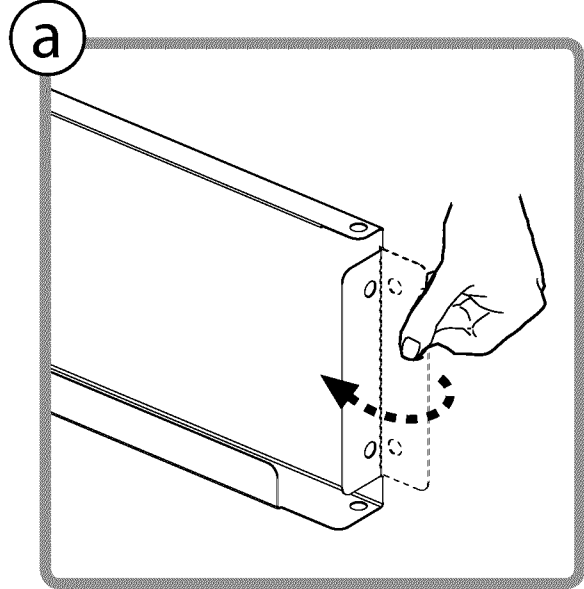
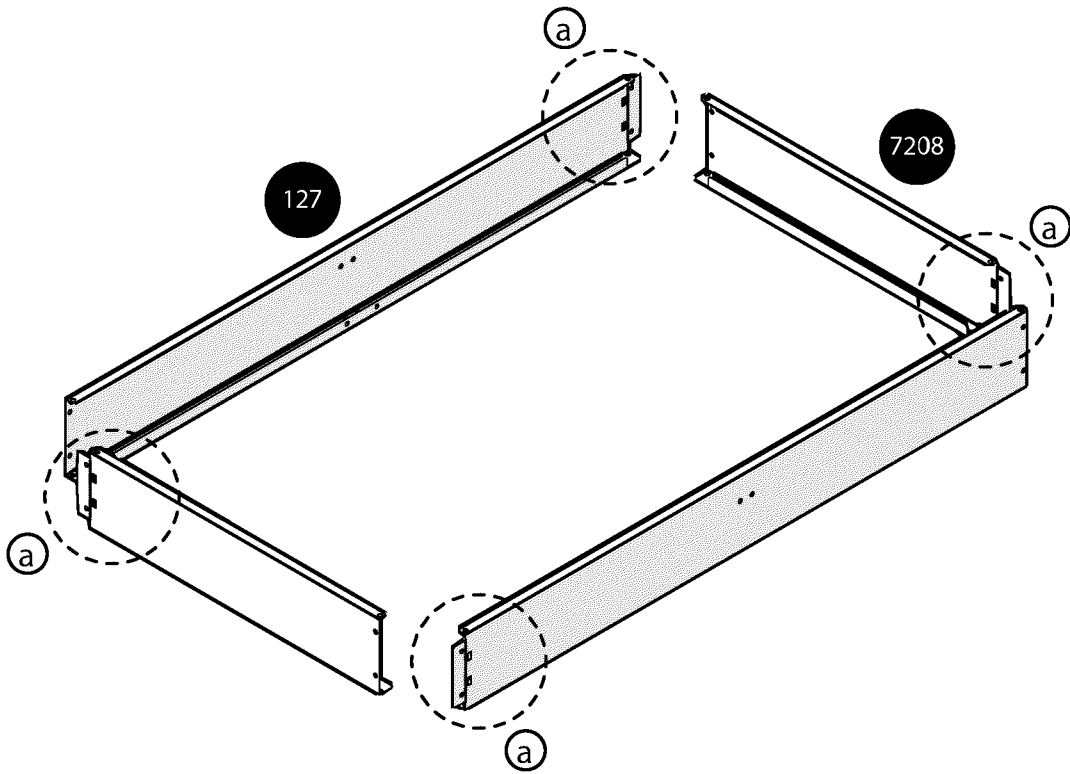
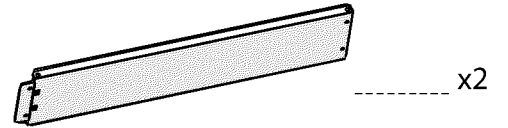

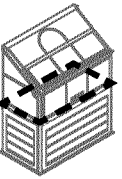

411  x16

412  x16

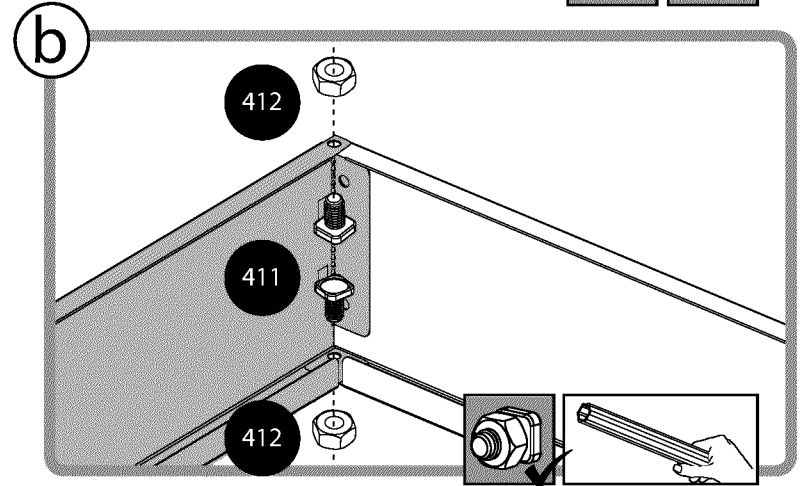
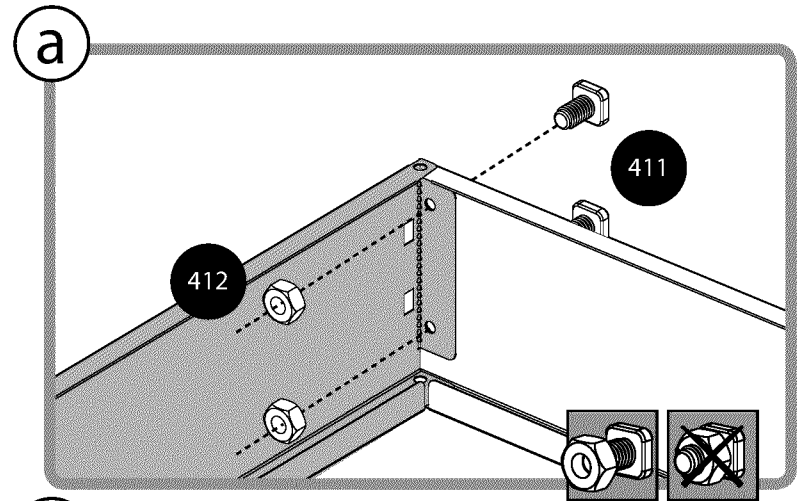
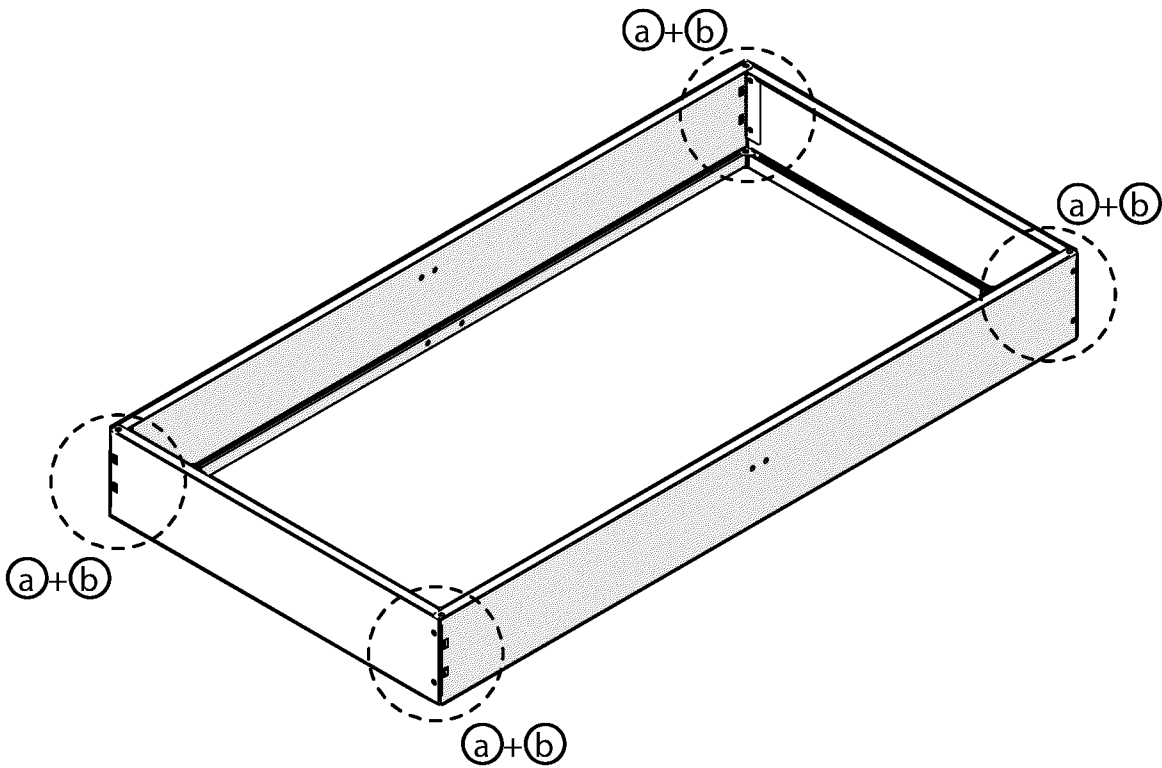

3

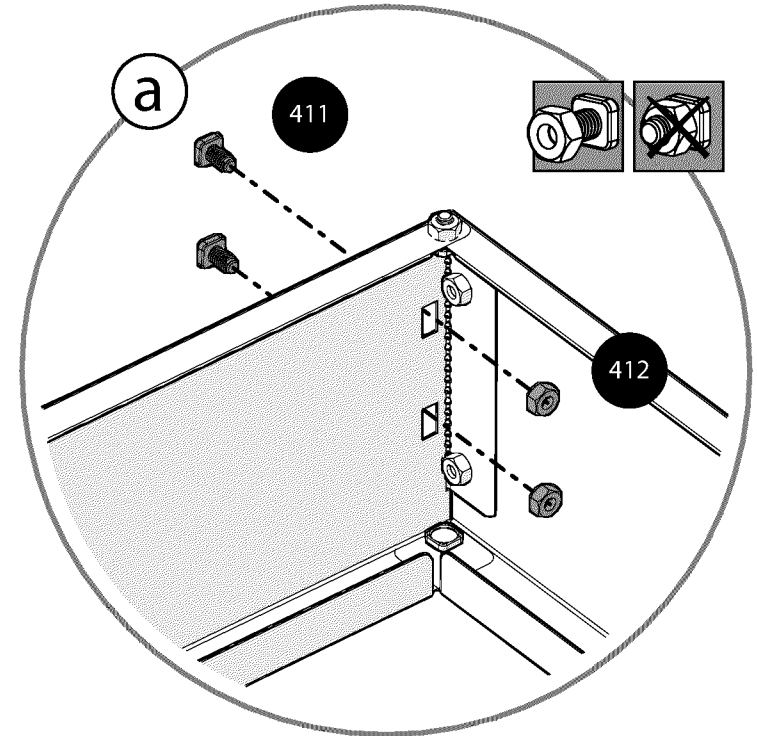
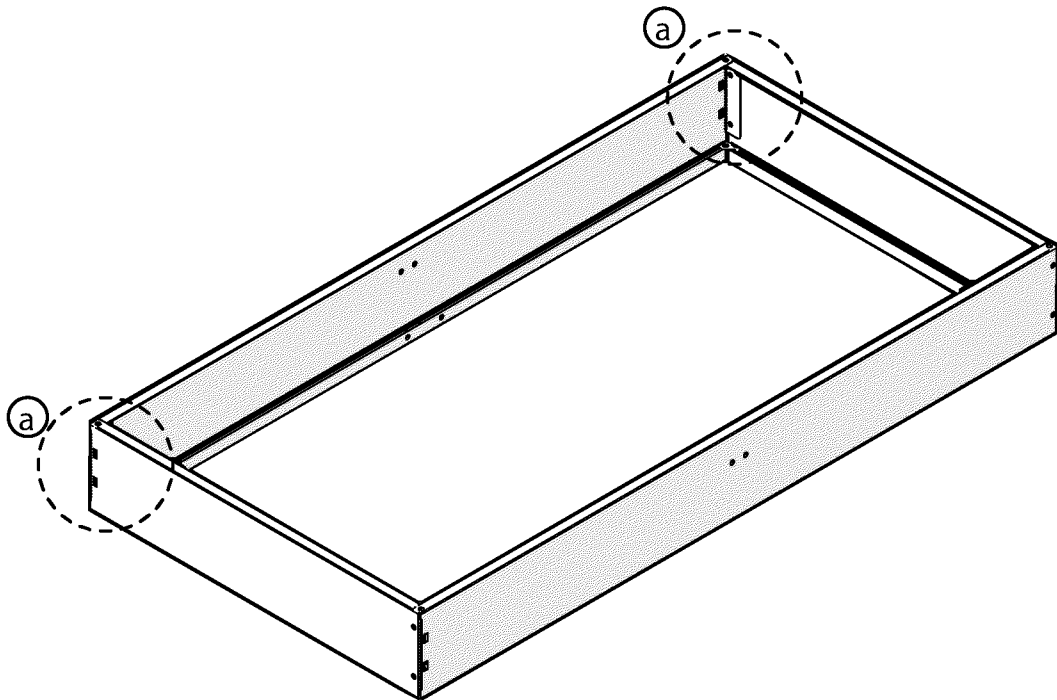
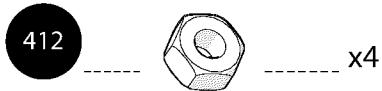

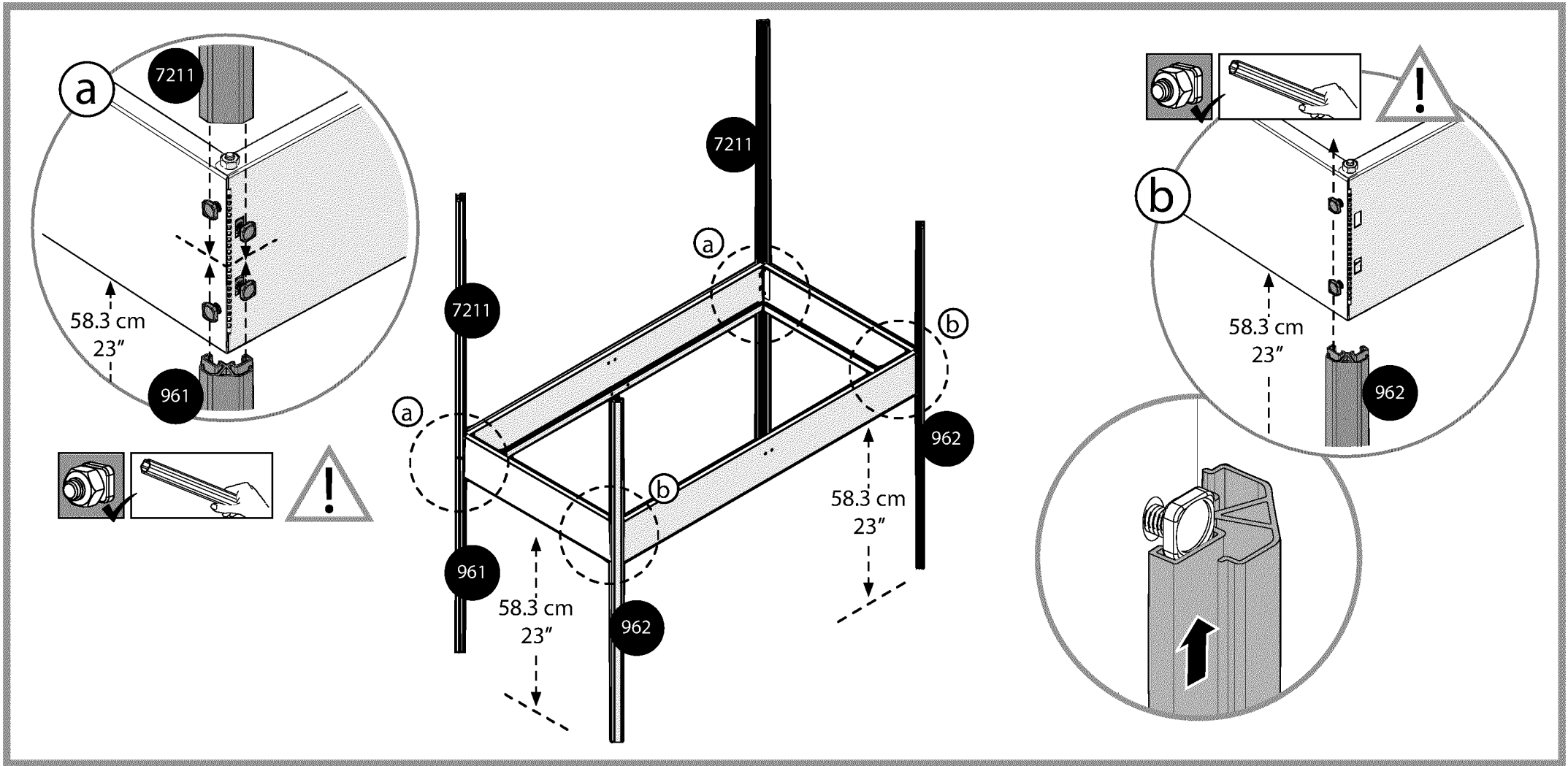
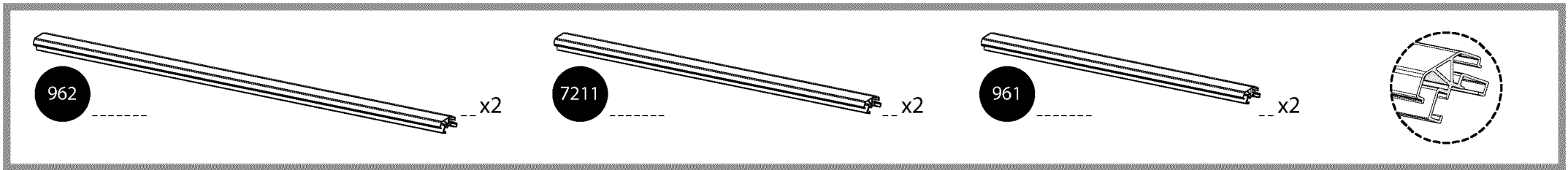
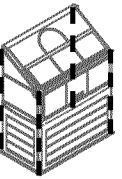

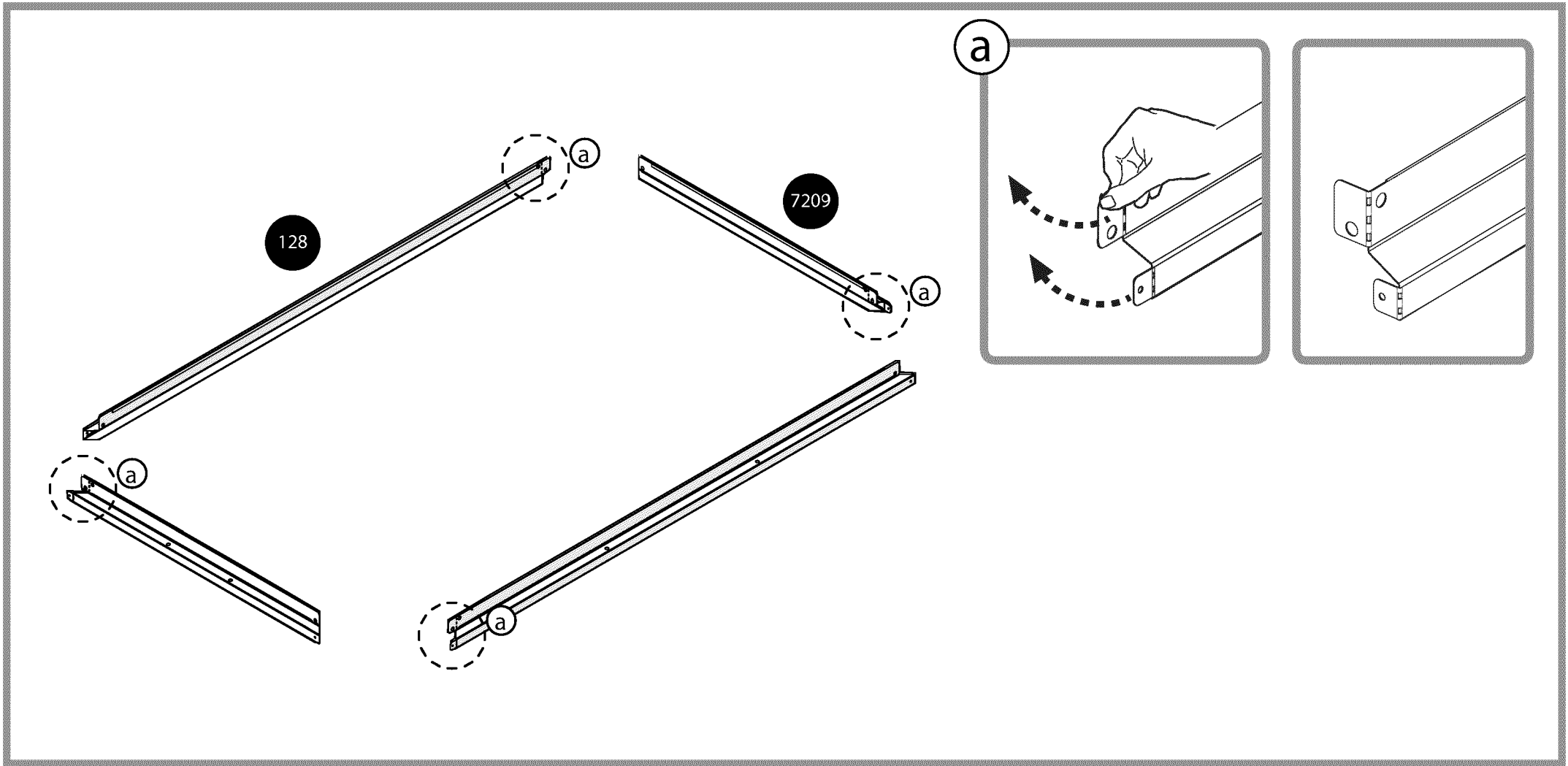
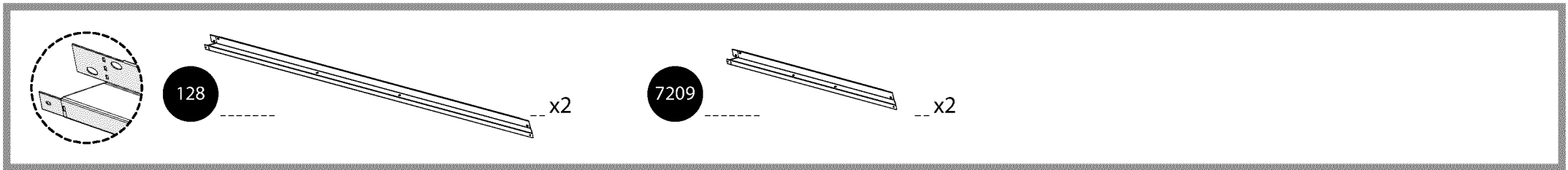
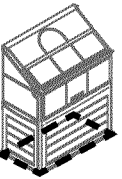

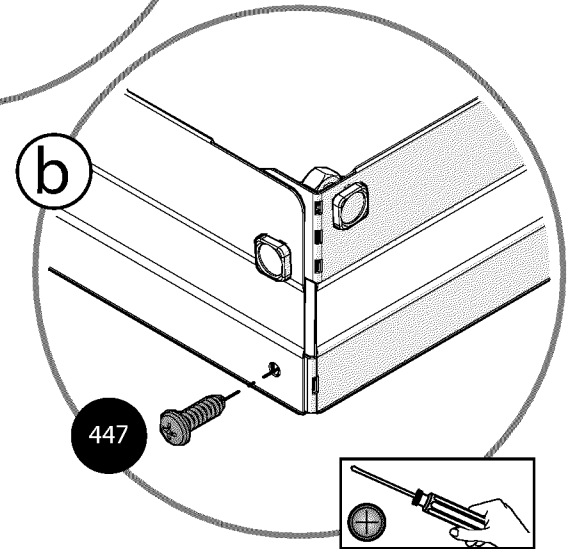
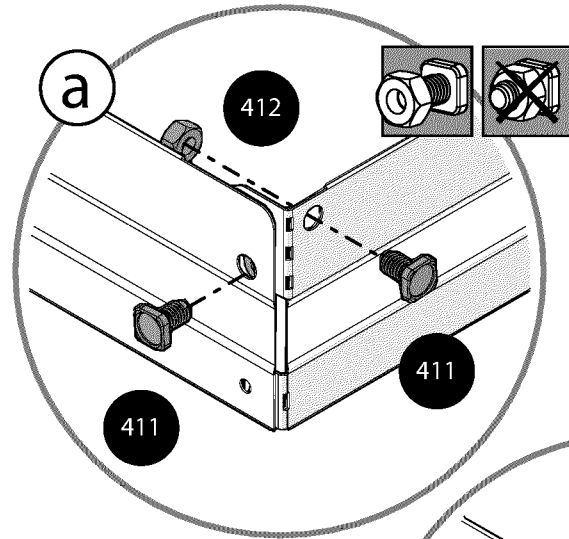
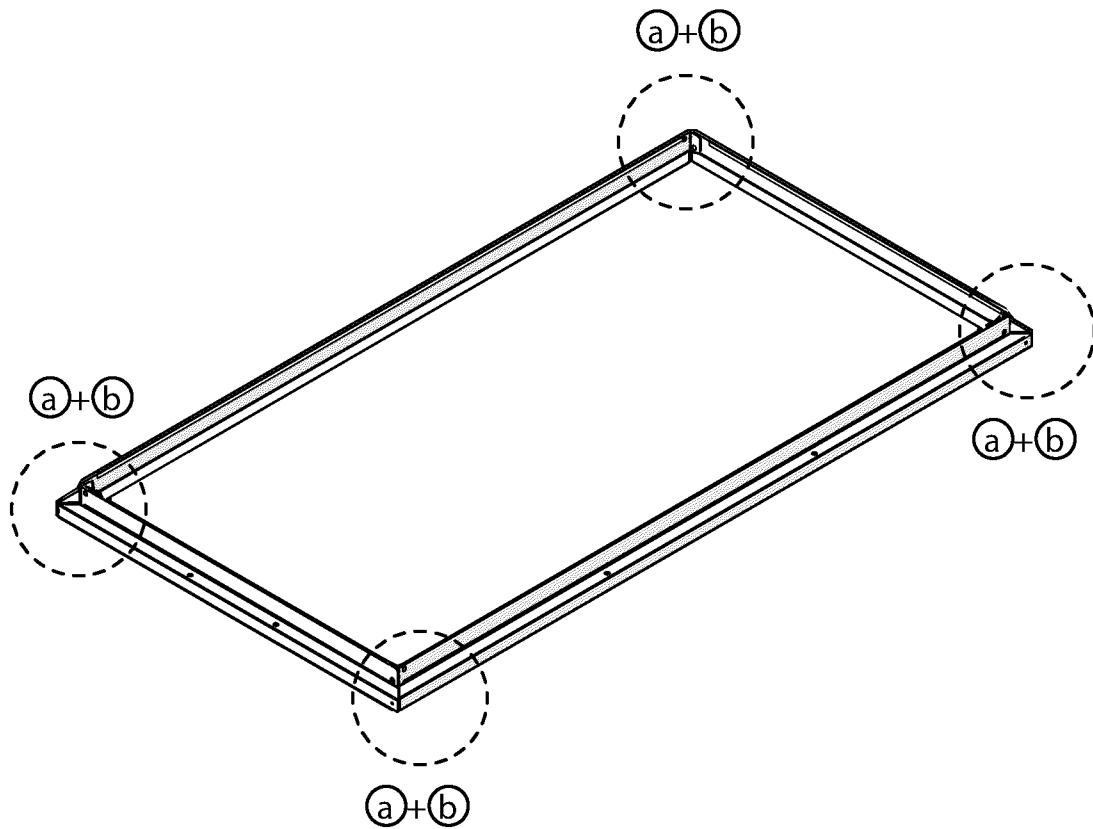
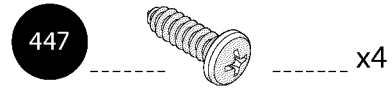
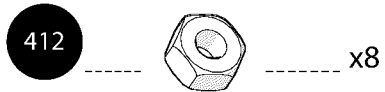
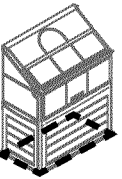

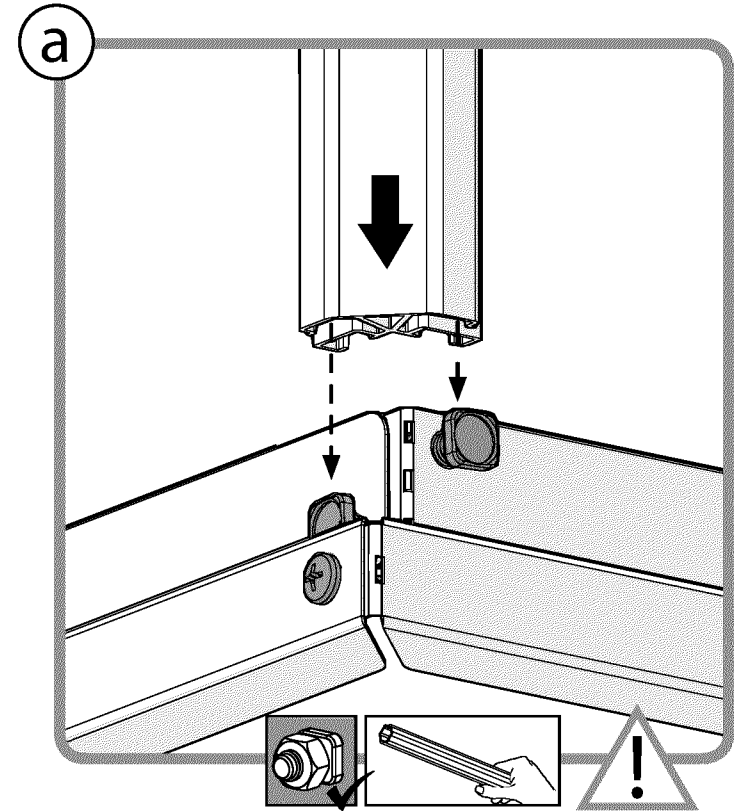
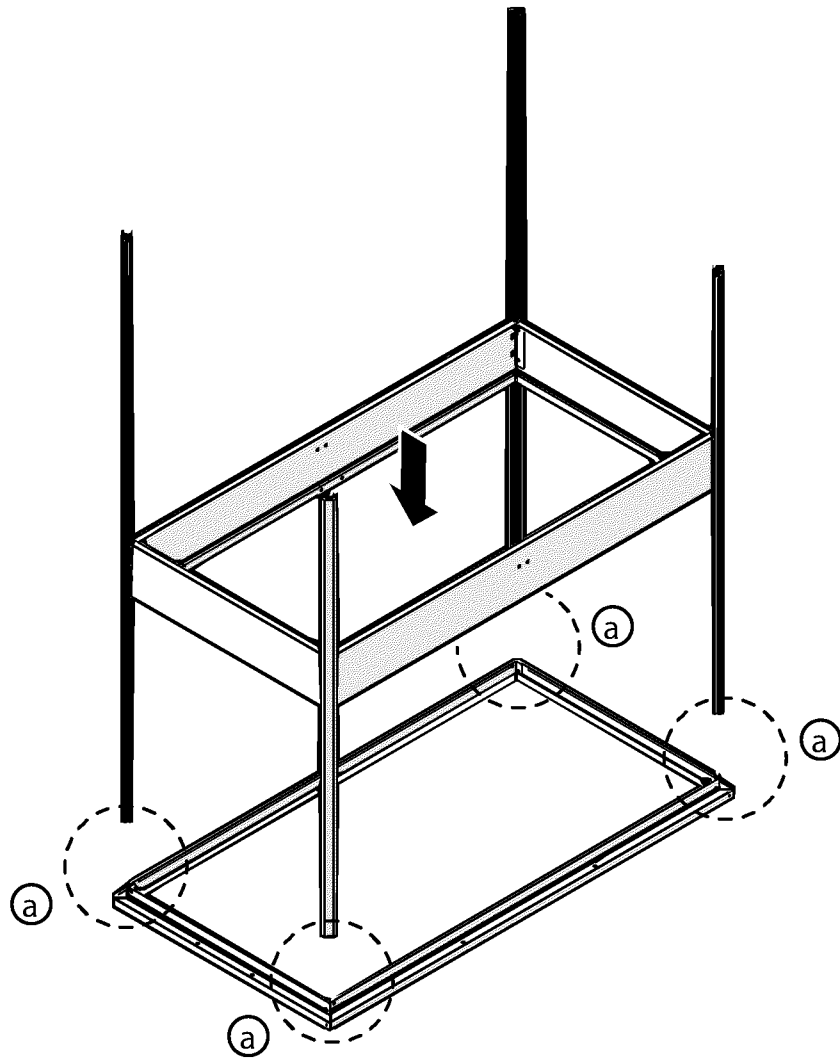
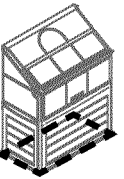

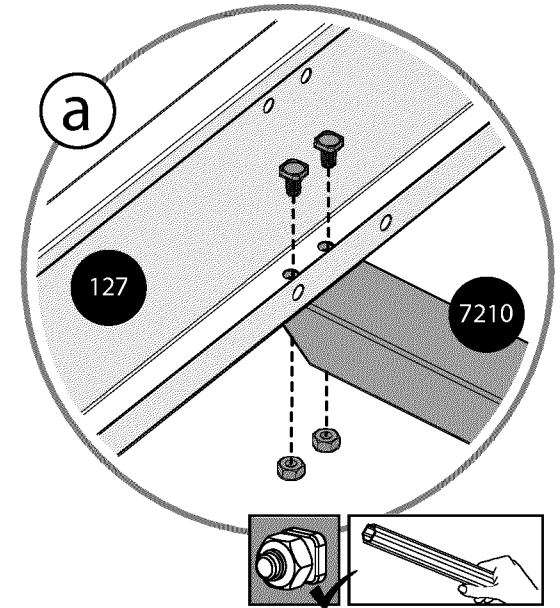
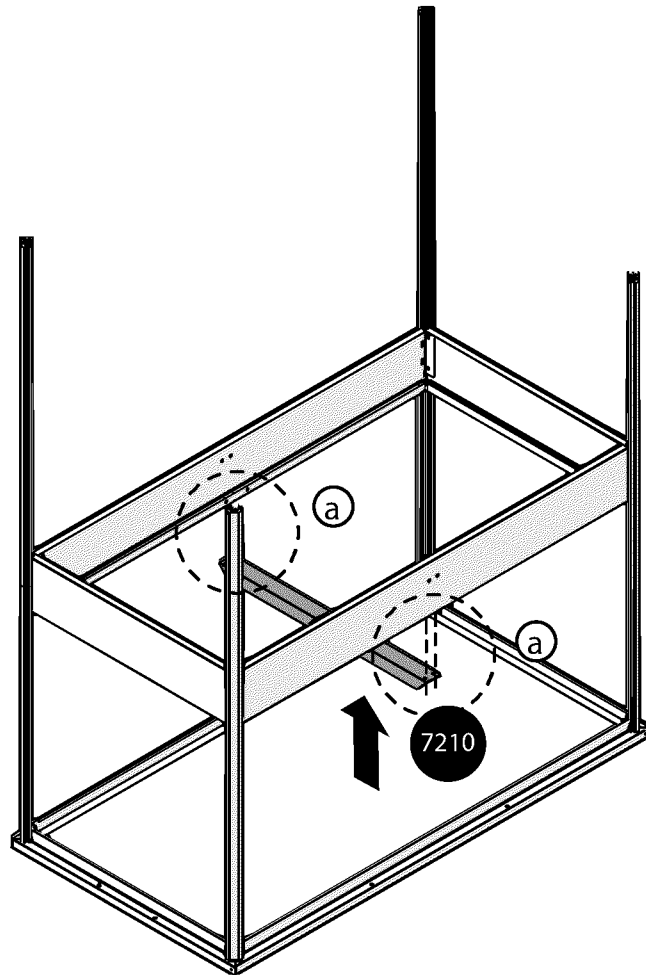
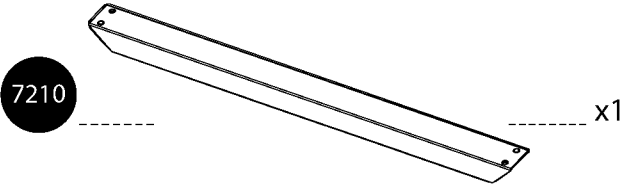
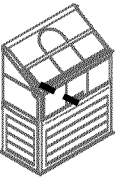

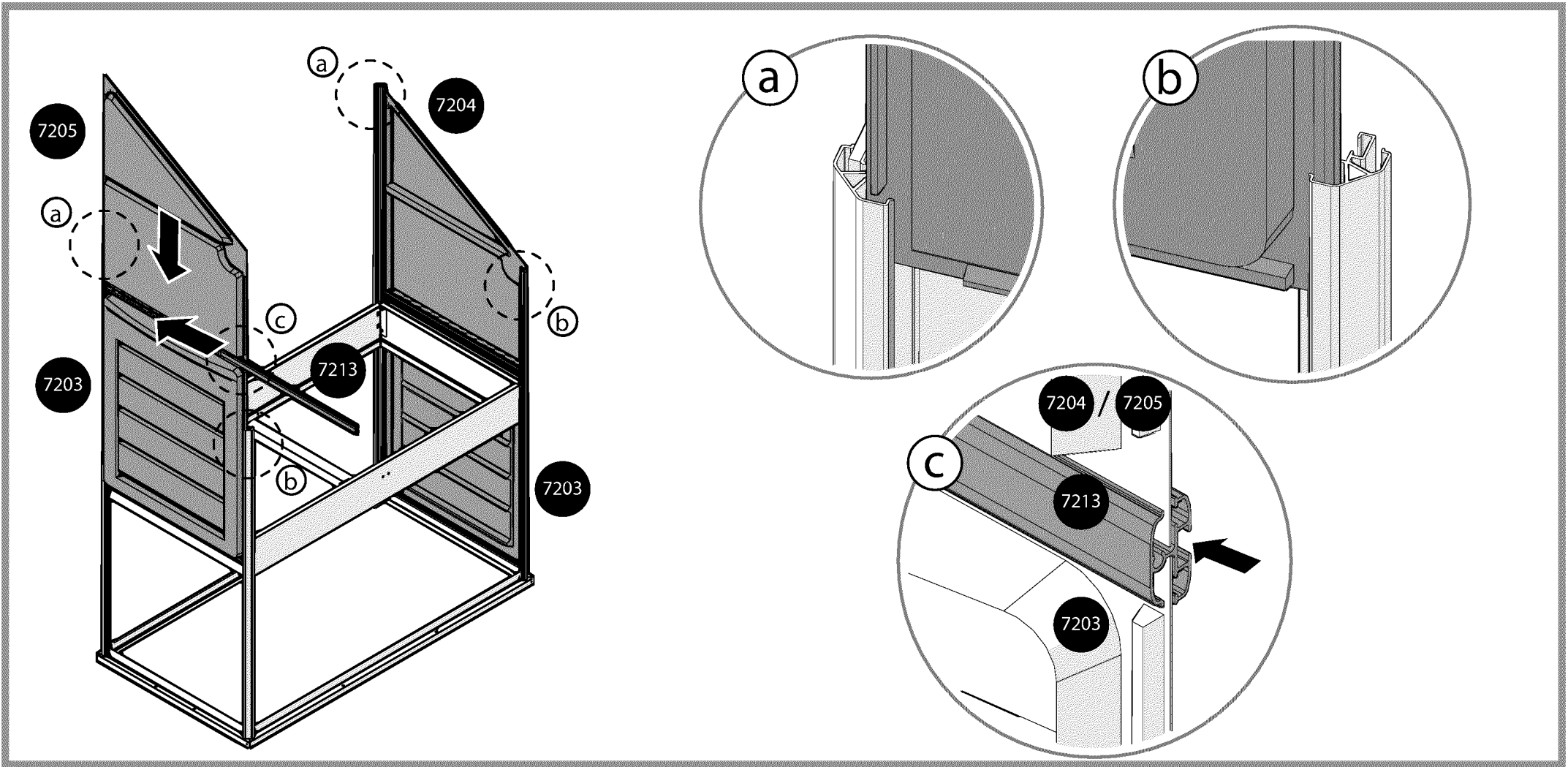
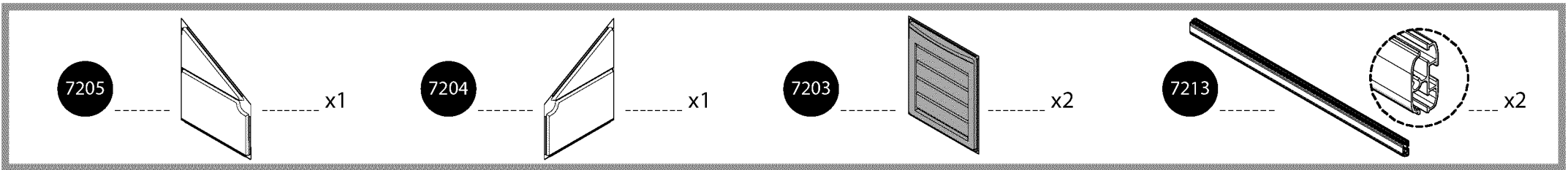

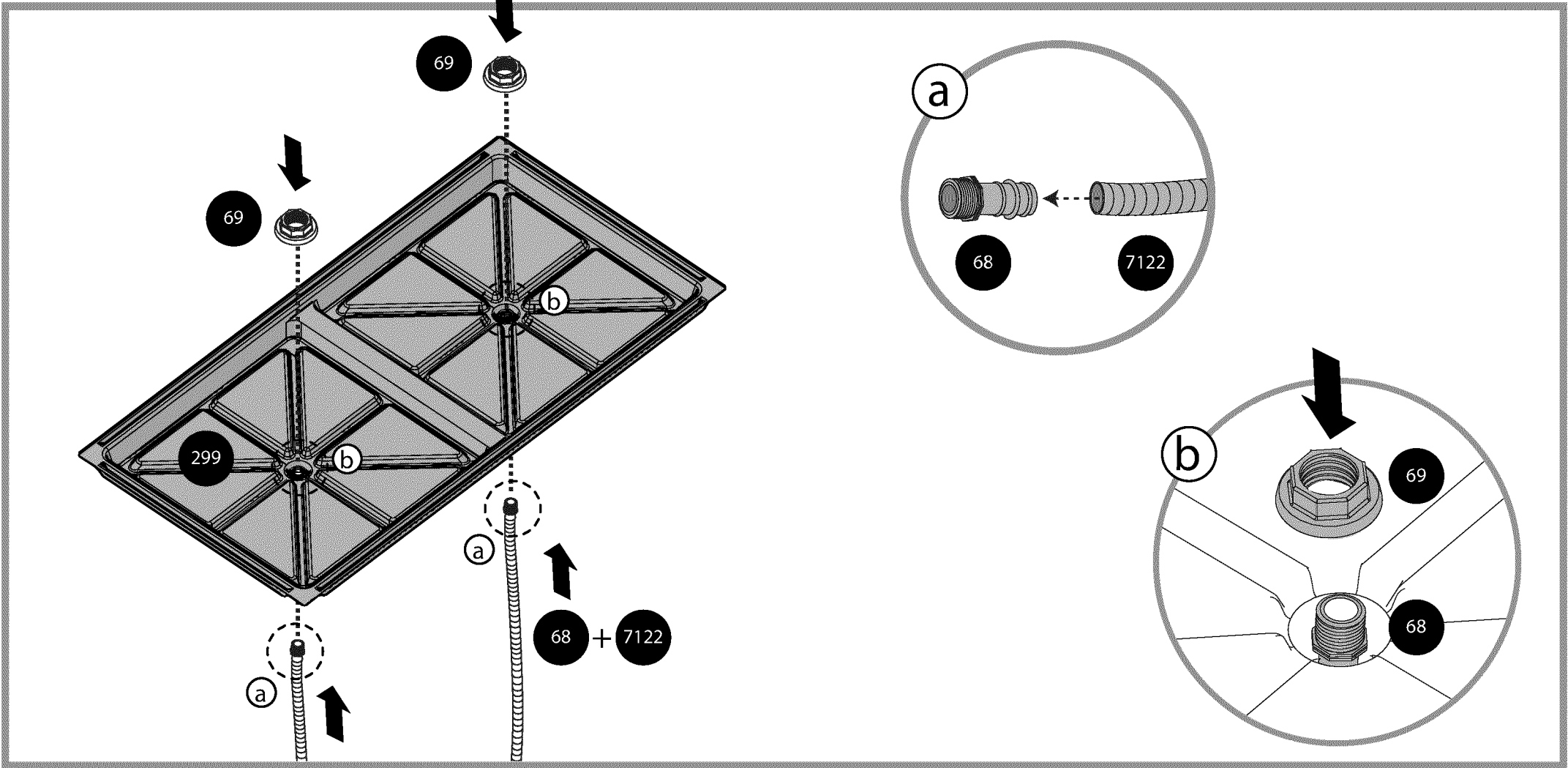
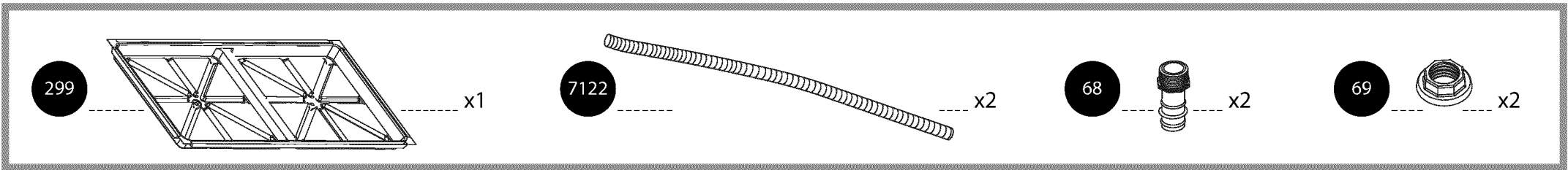
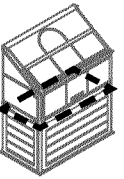

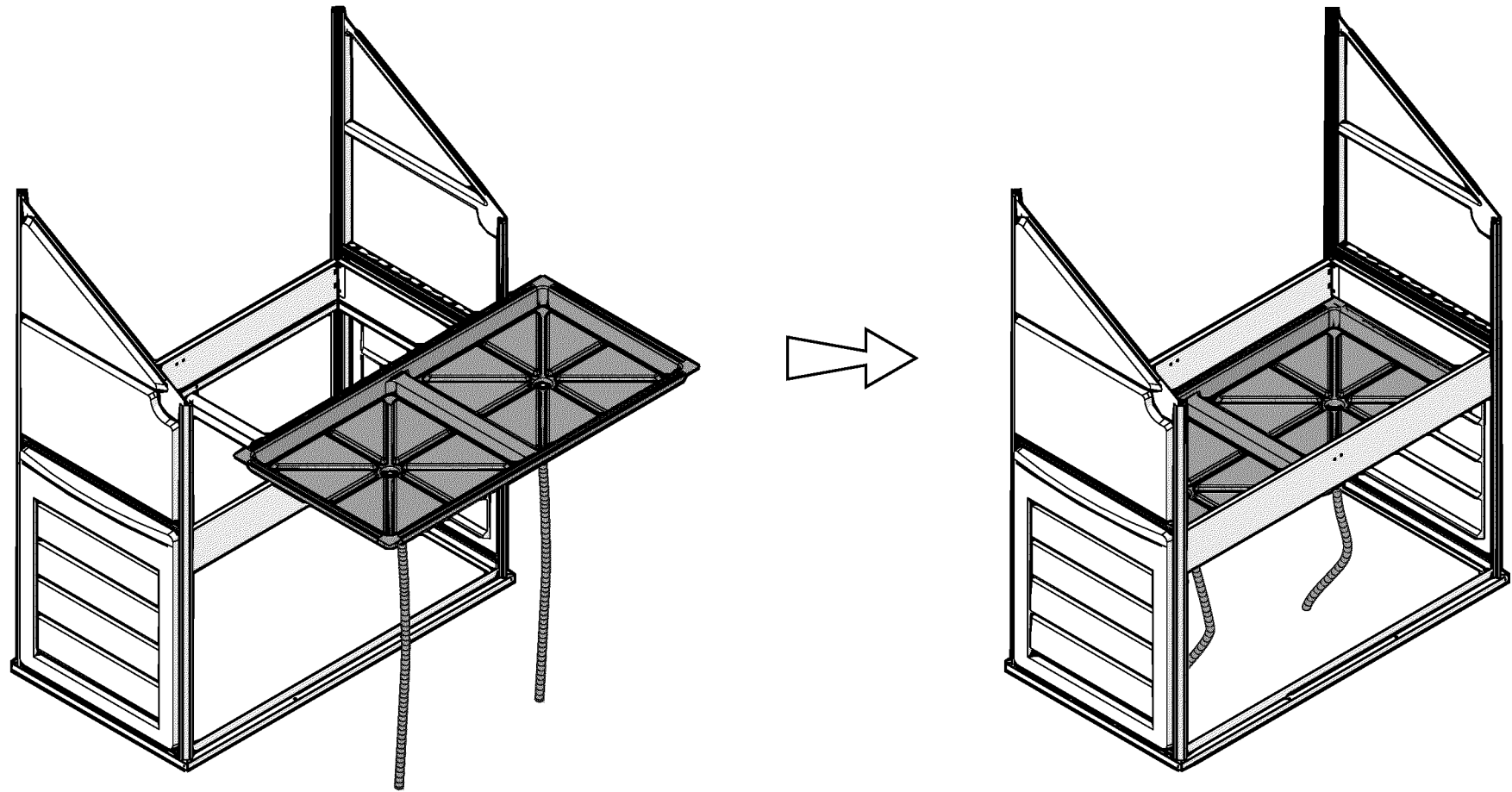
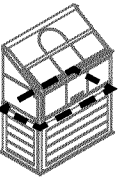

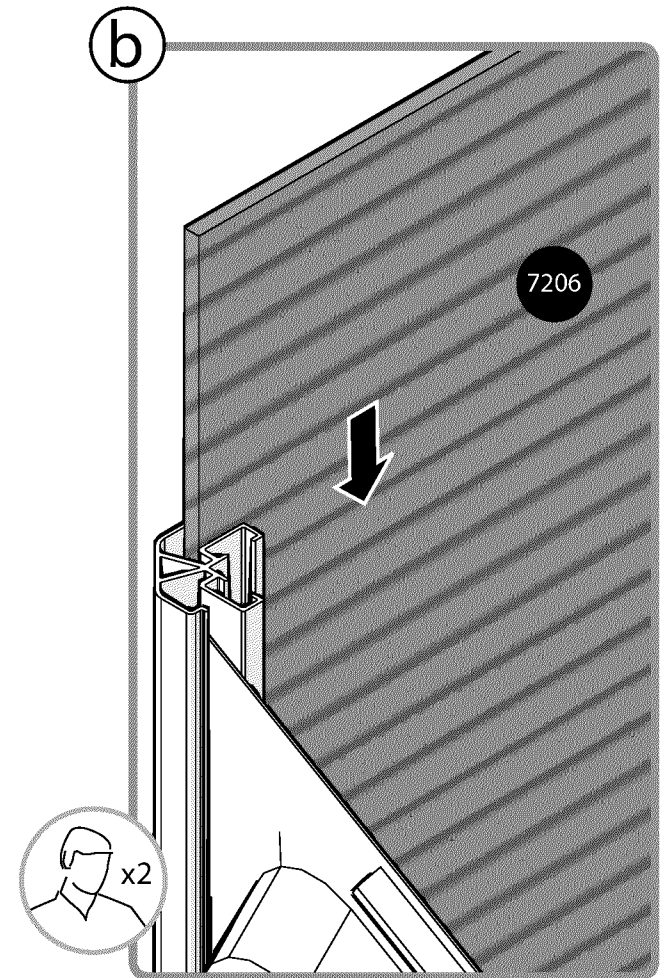
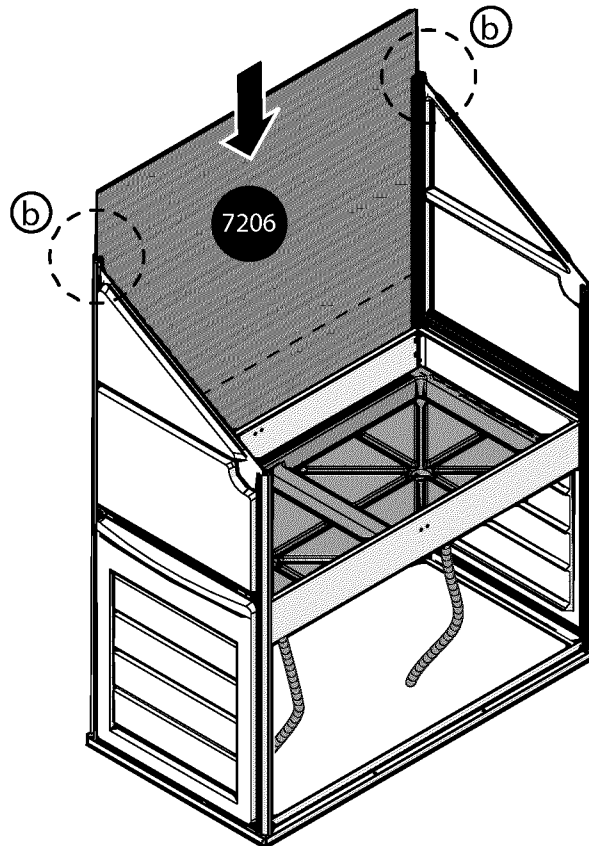
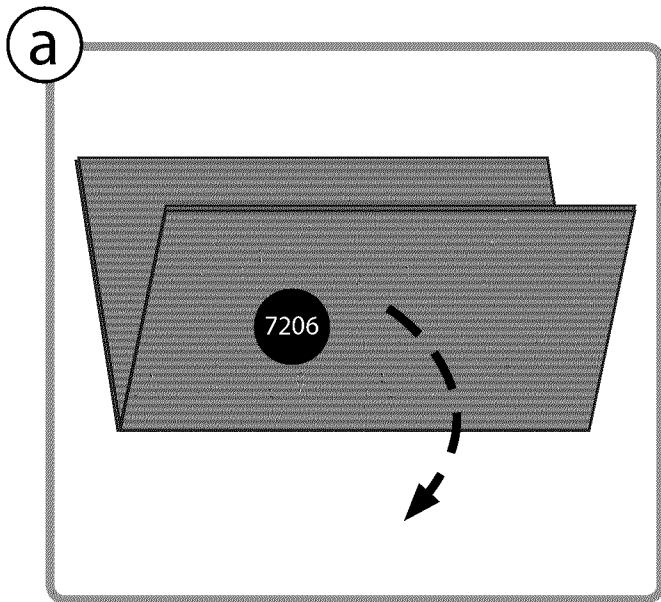
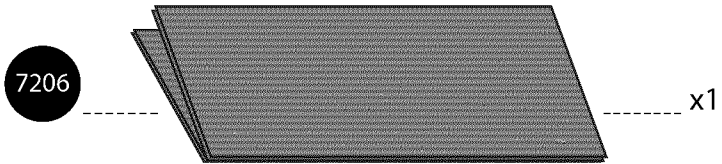
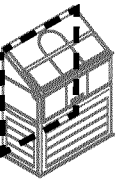

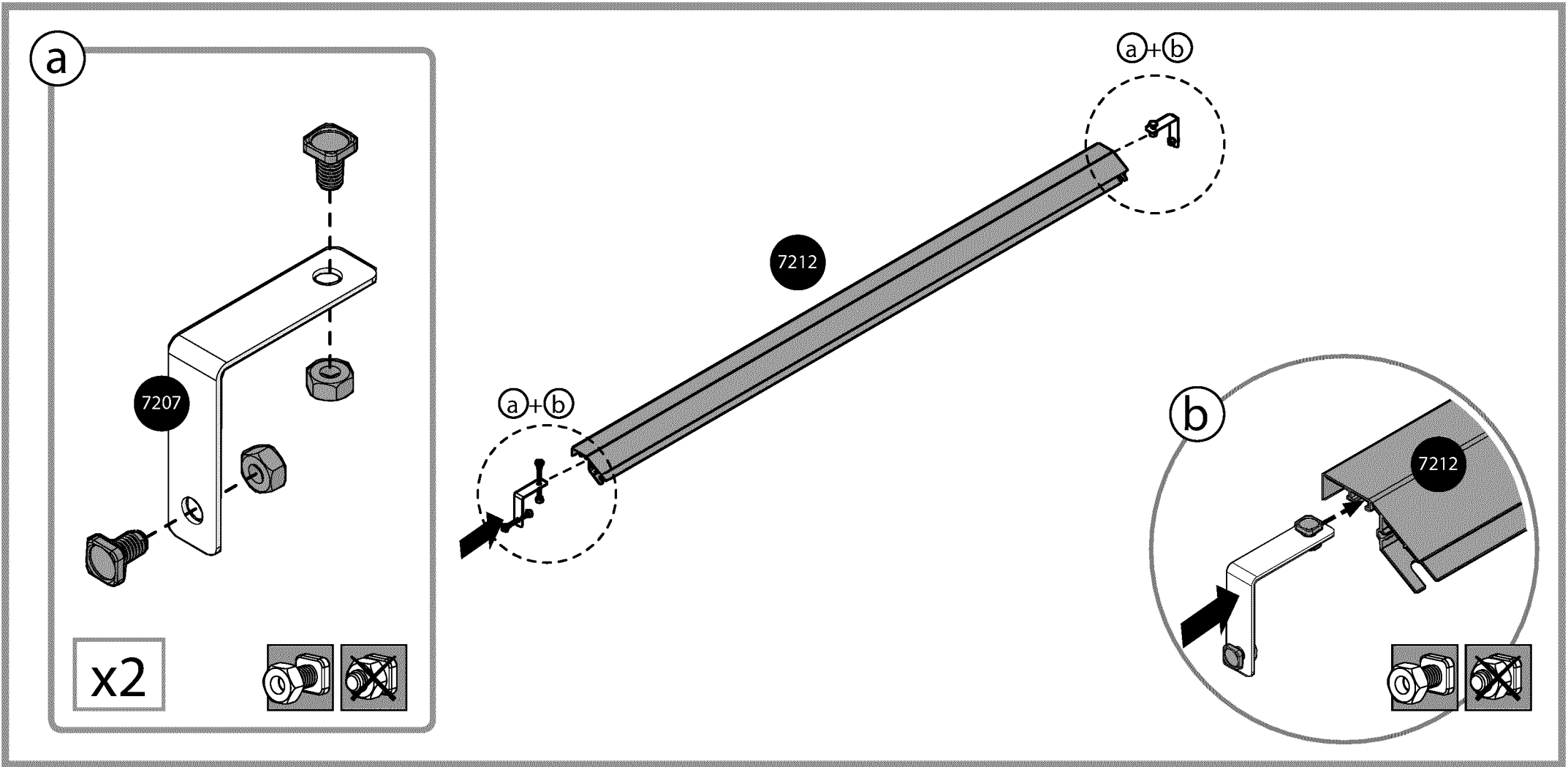
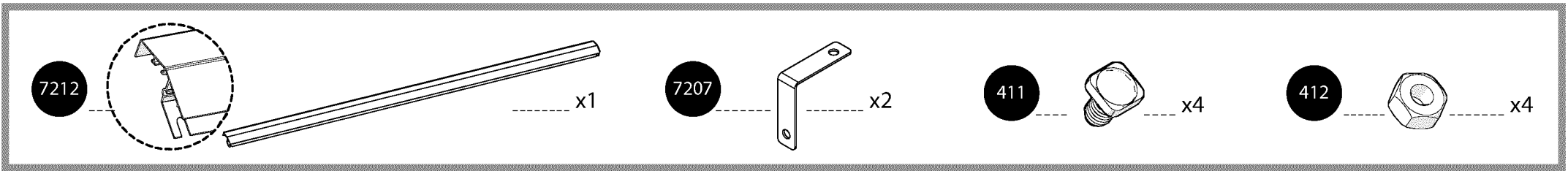

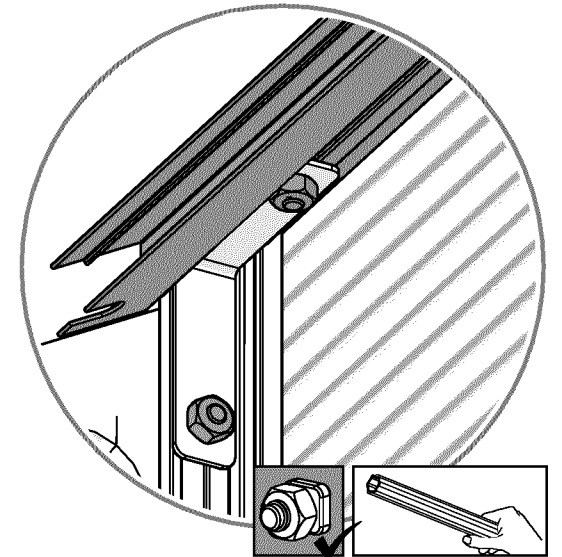
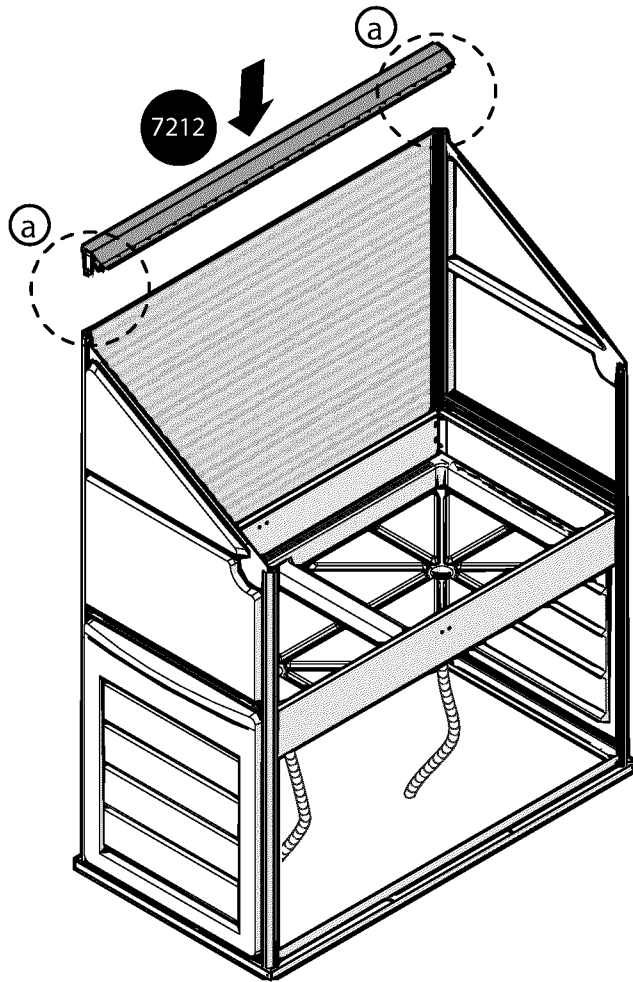
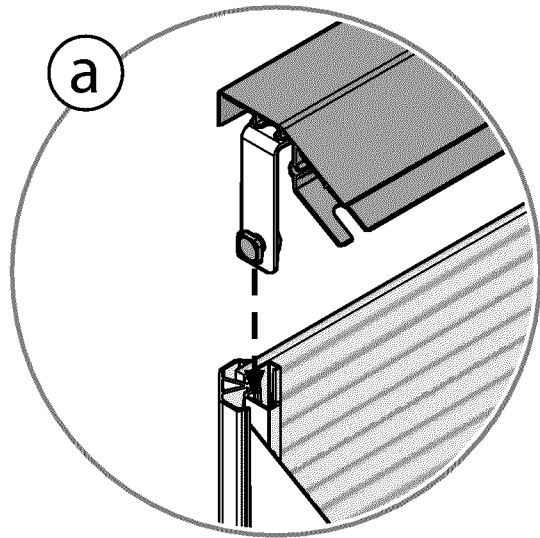

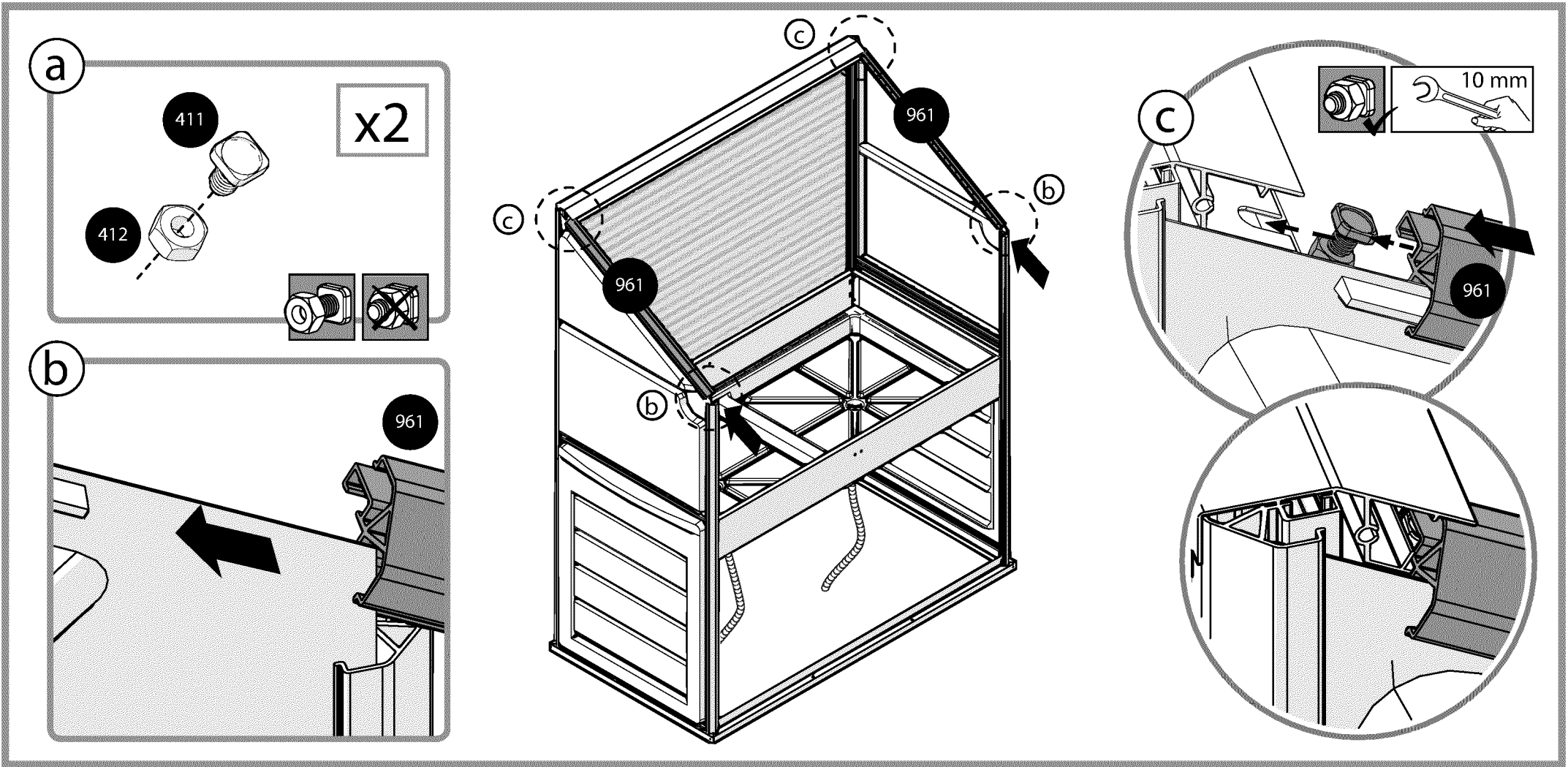
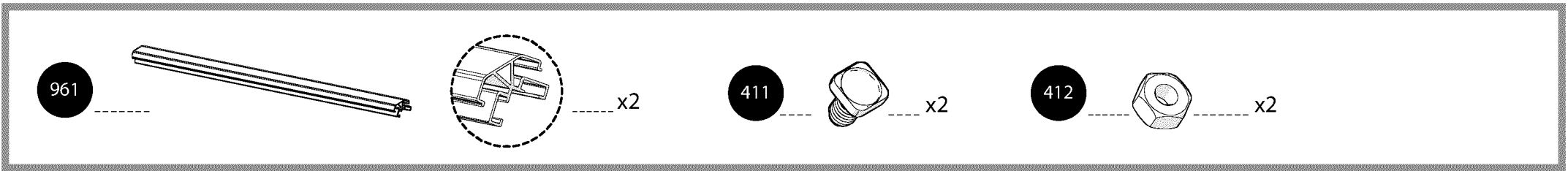

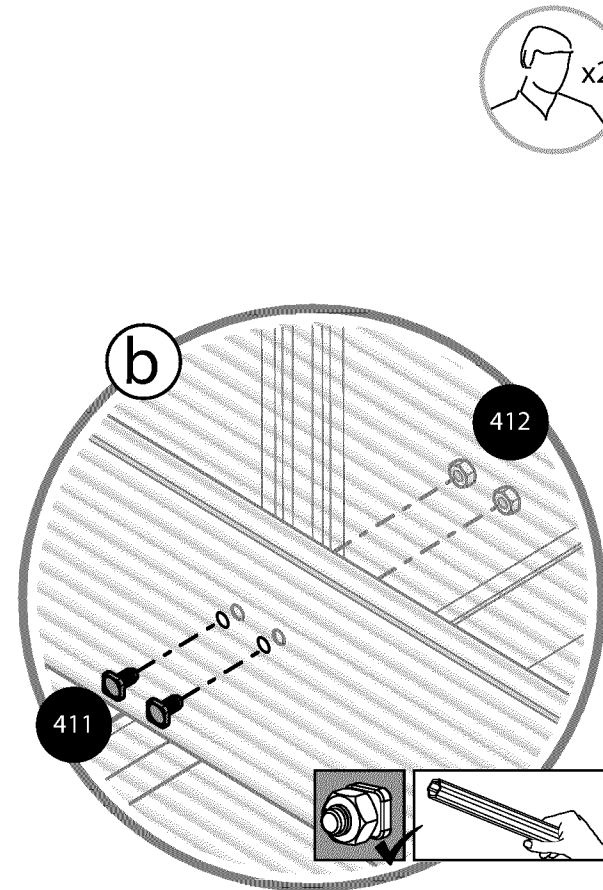
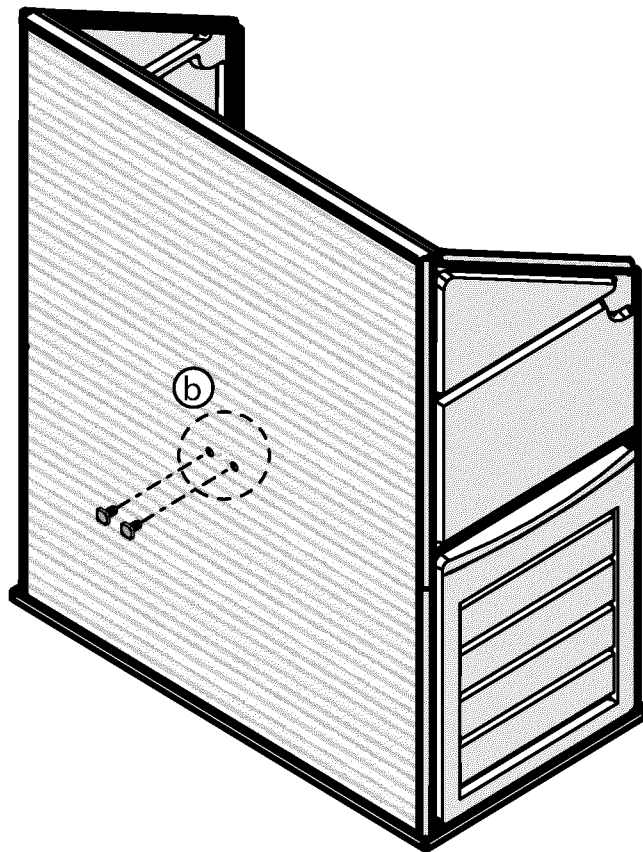
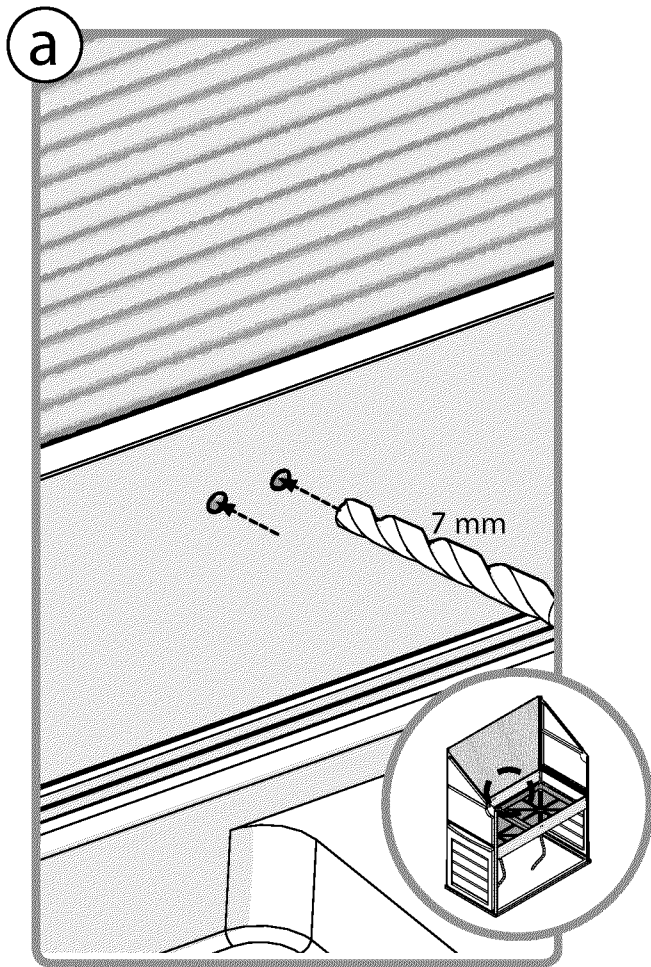
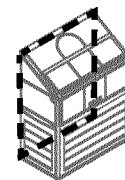

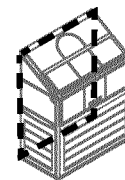

328

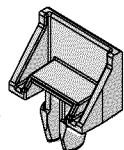

x2

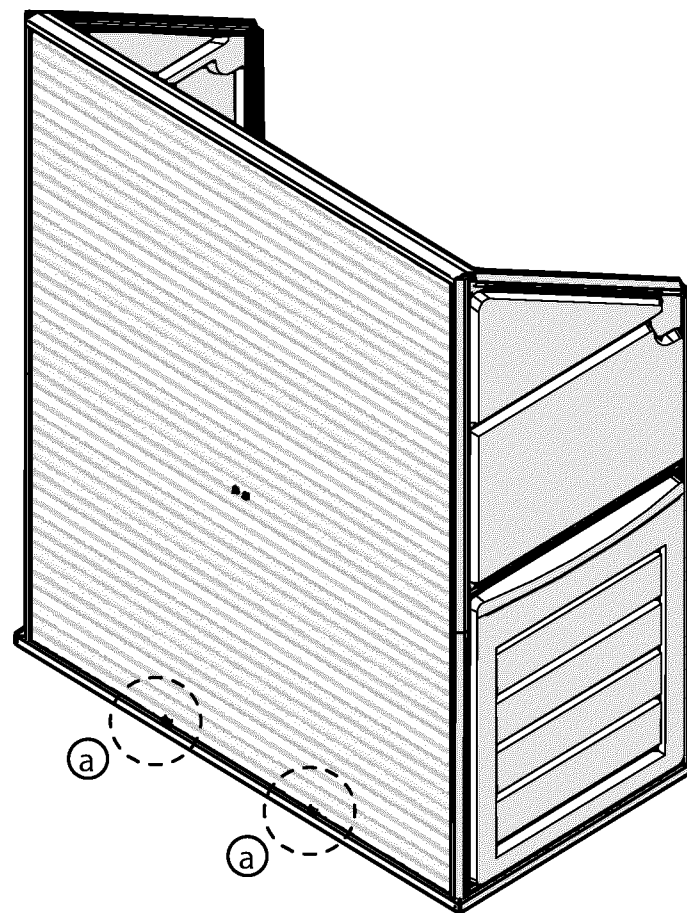
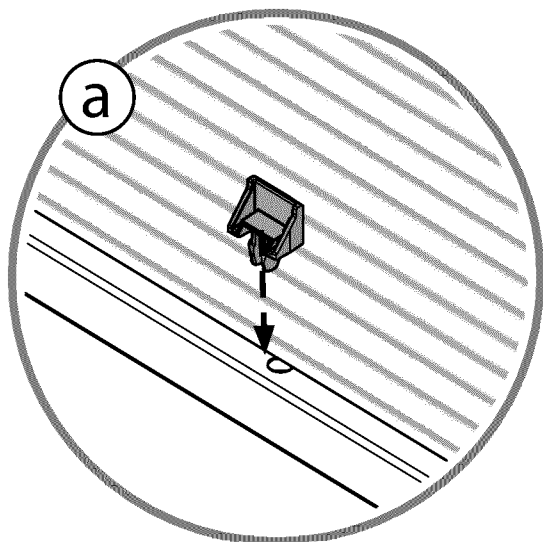

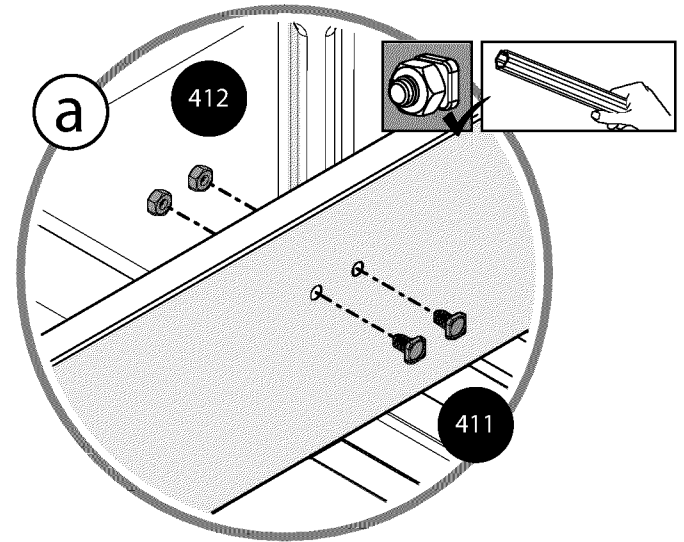
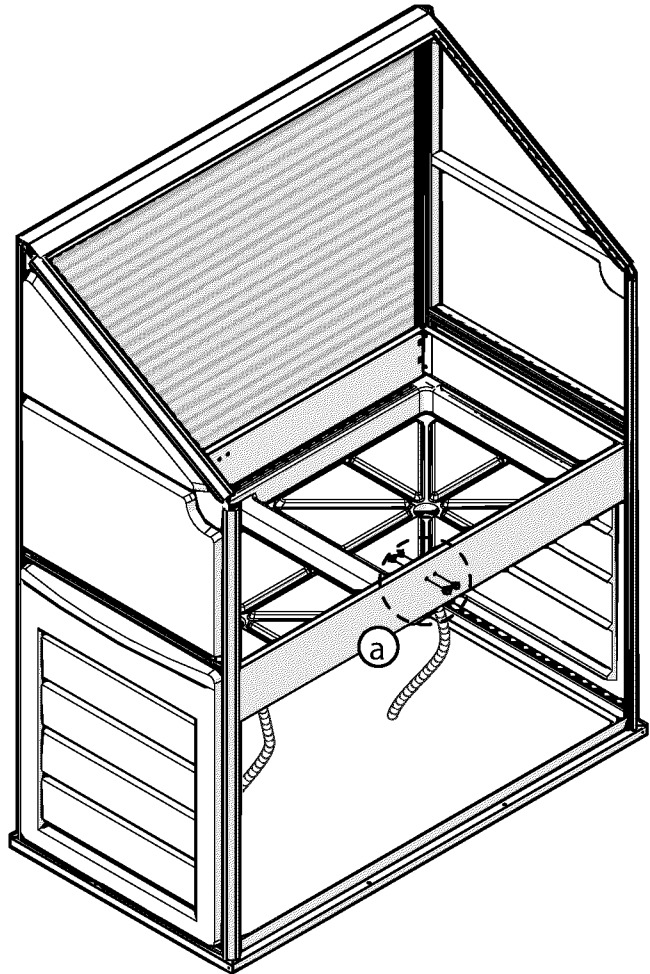



298

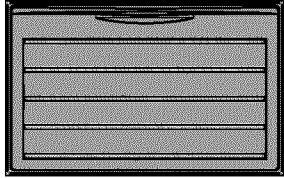

.... x1

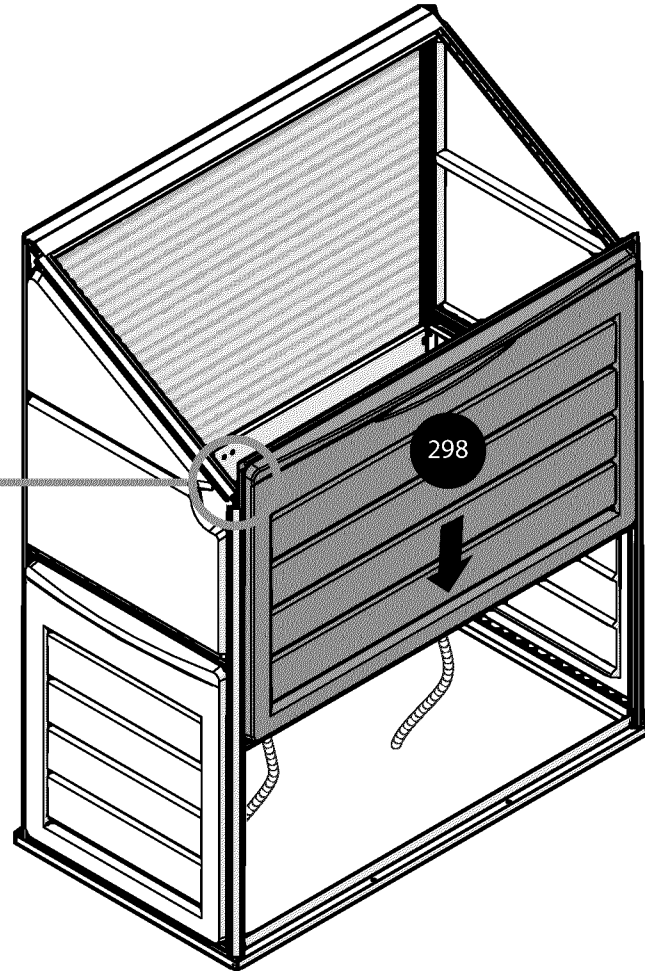
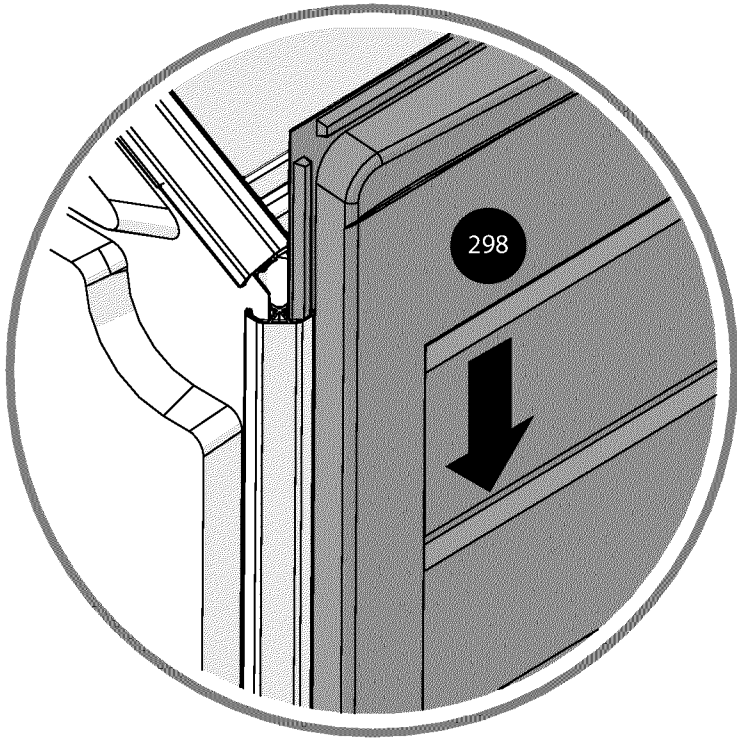



139

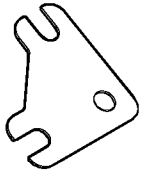

x2

412



x4

411



x4

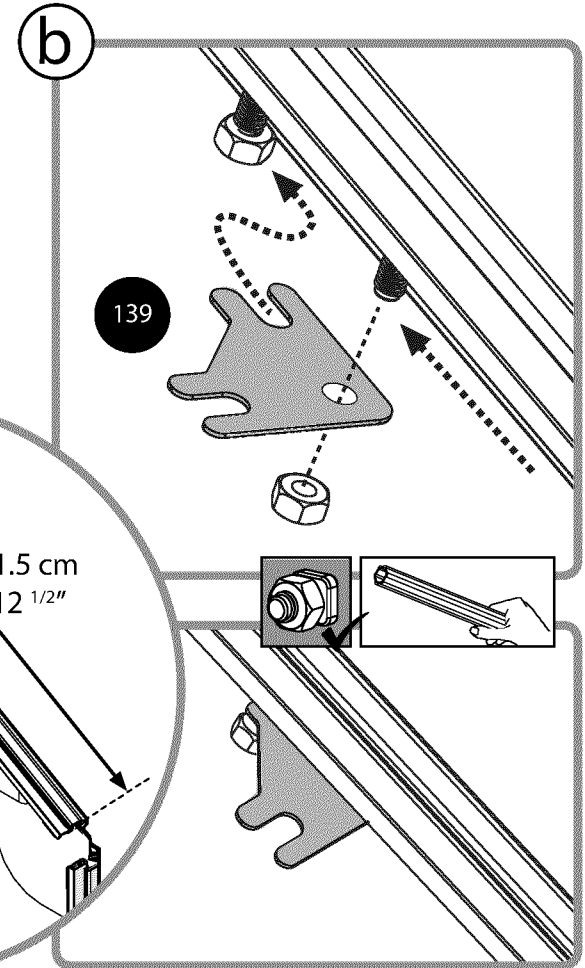
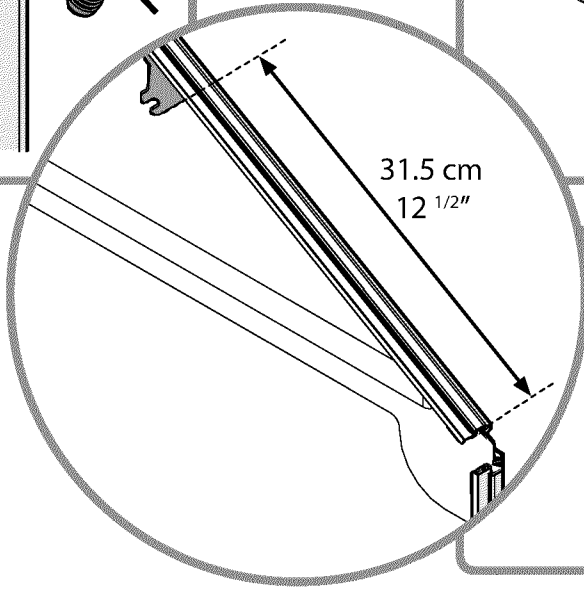
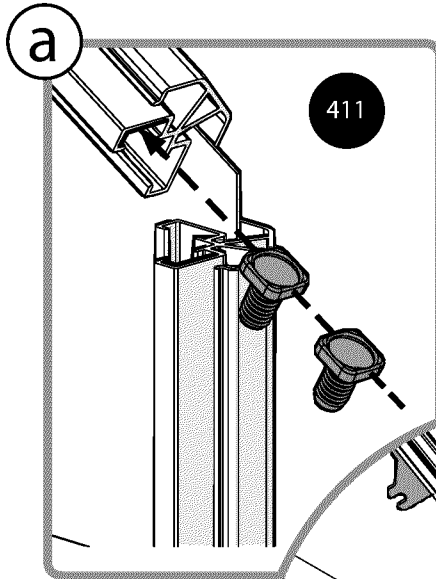
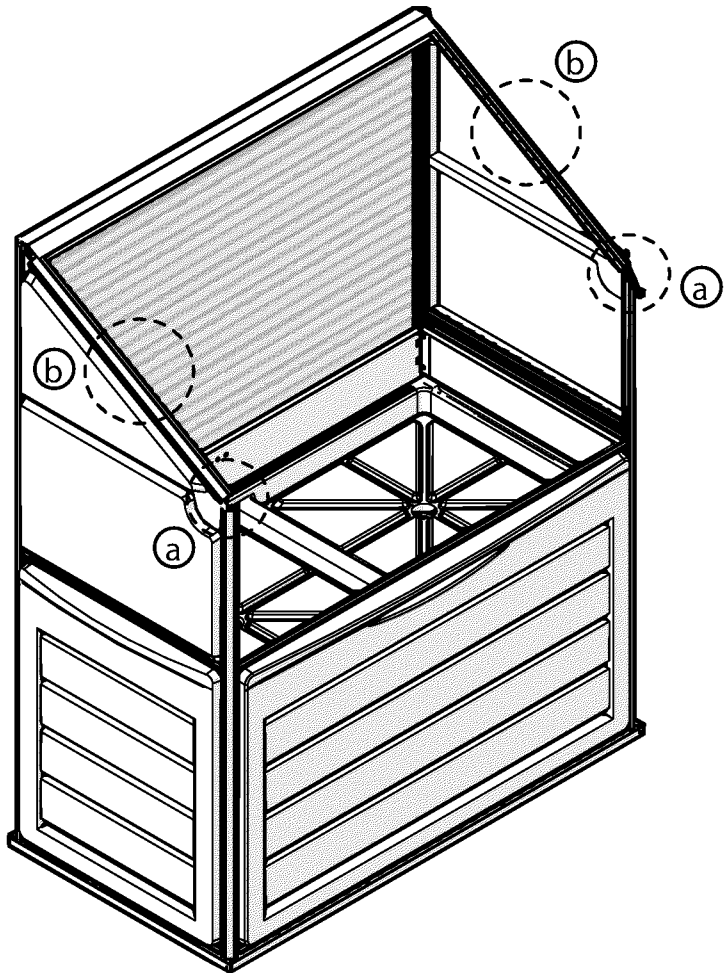

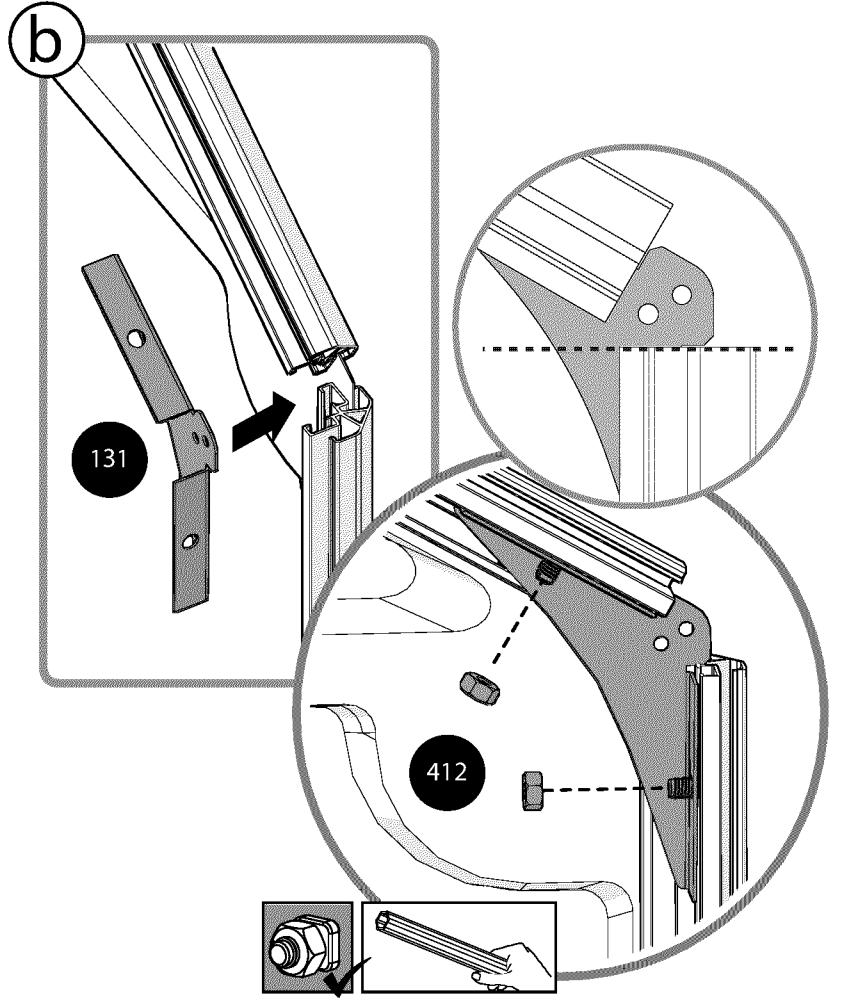
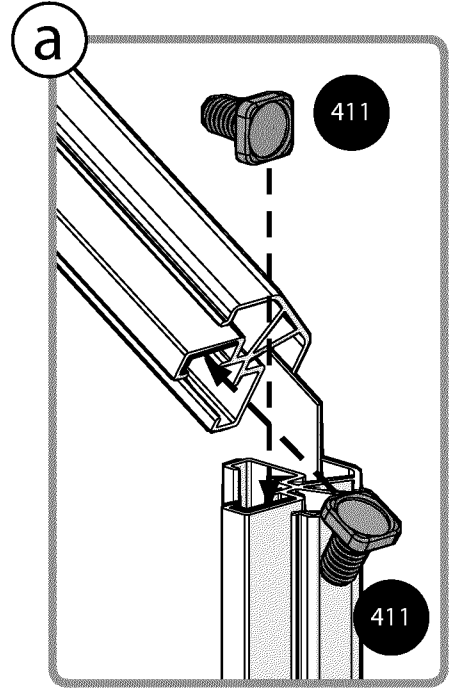
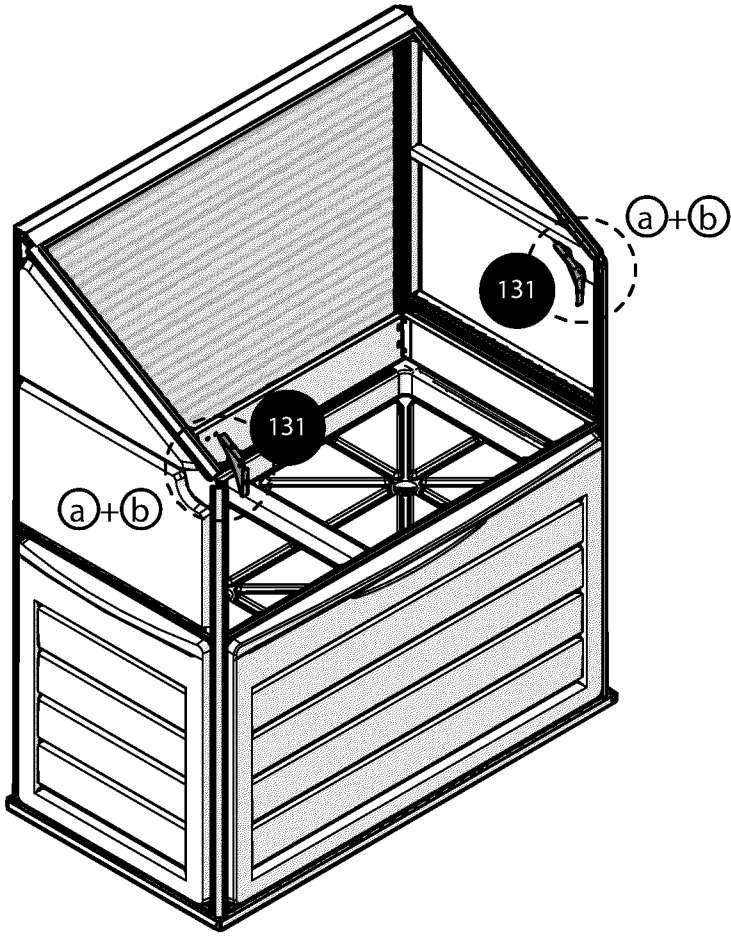
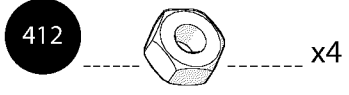
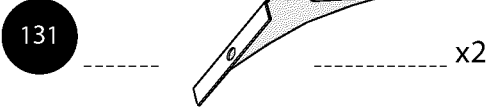
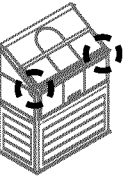

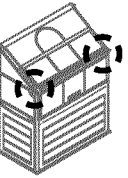

302

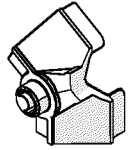

x2

4026

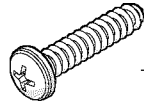

x2

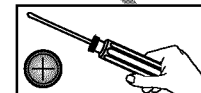
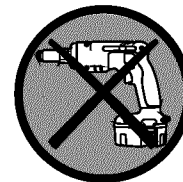
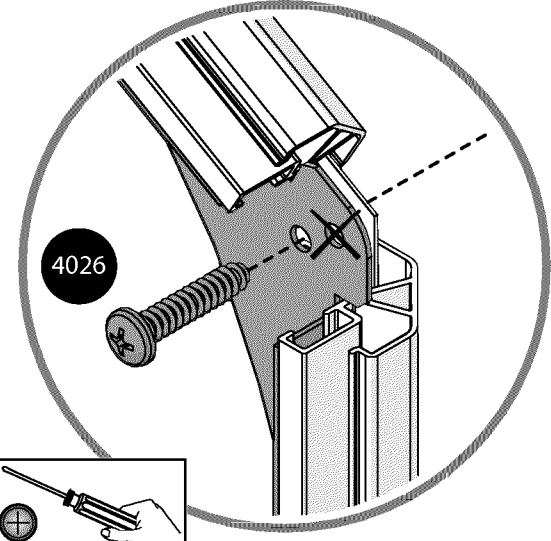
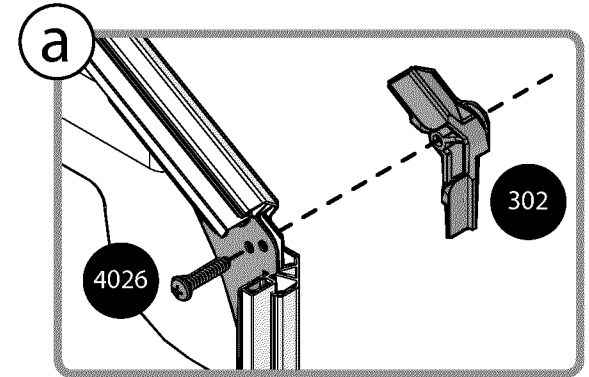
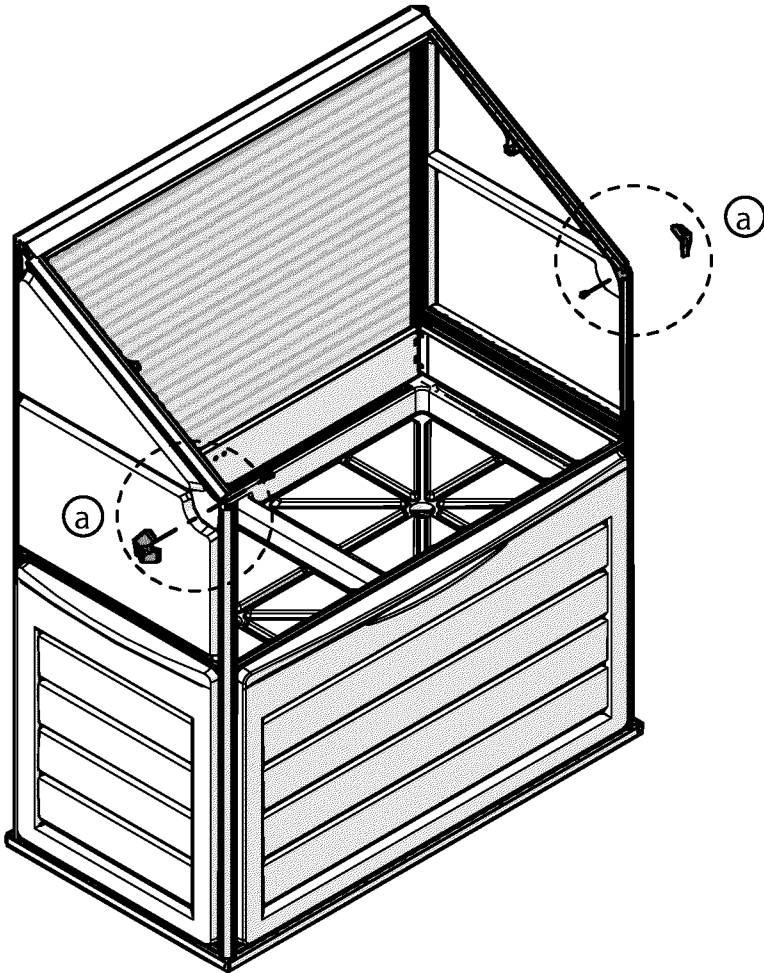



7202
Left

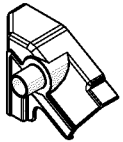

x1

7202
Right

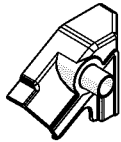

x1

447

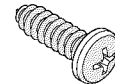

x2

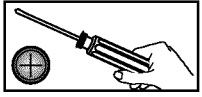
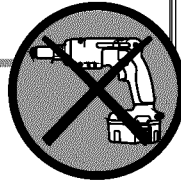
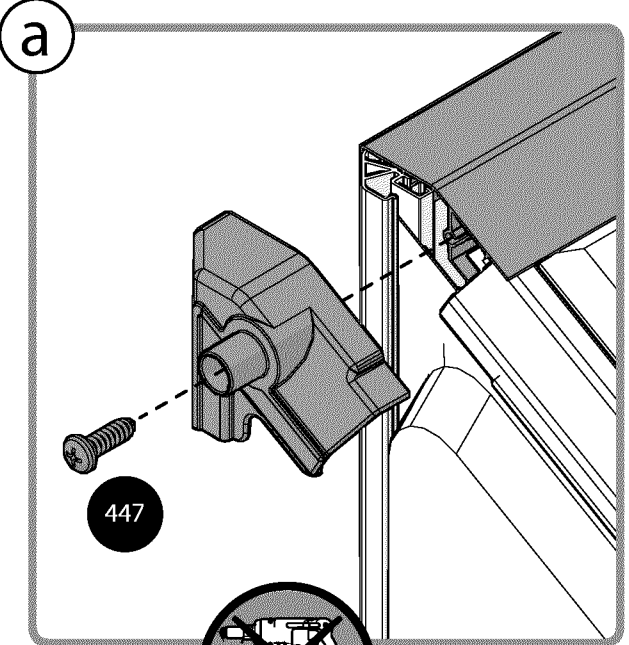
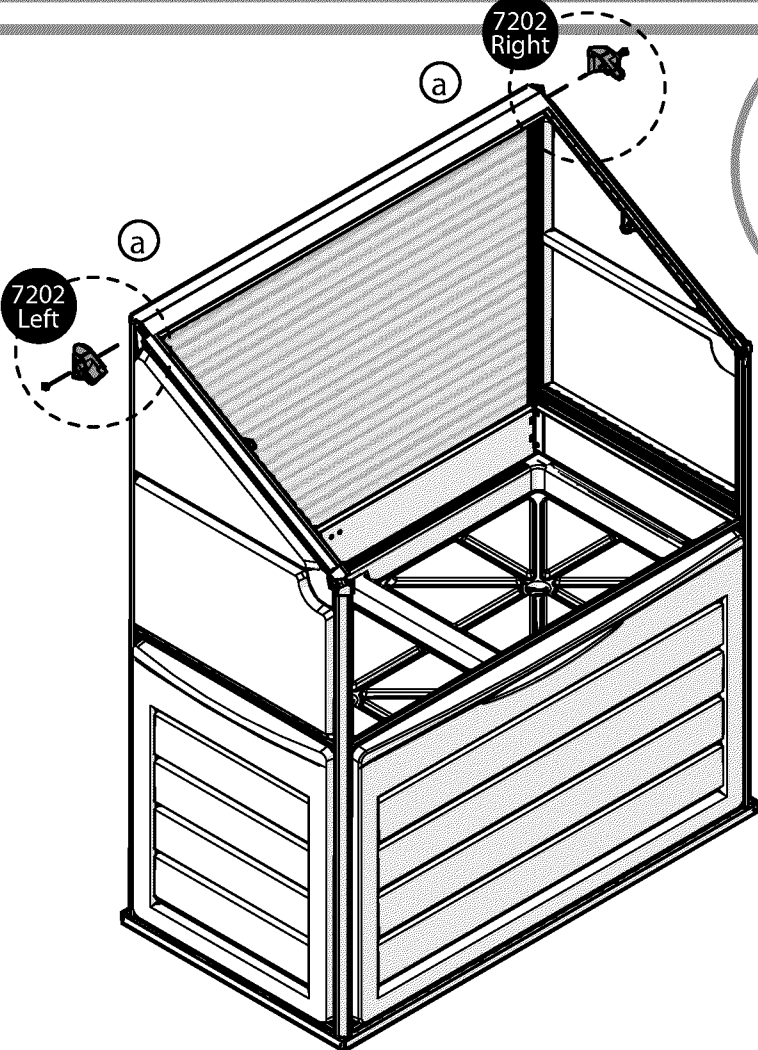
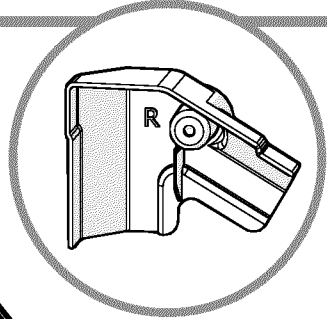
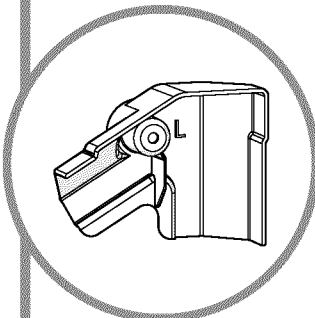



295

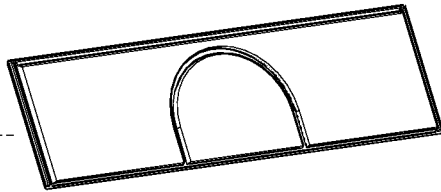

x1

318

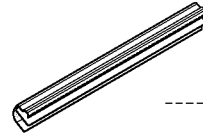
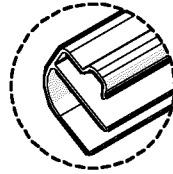

x1

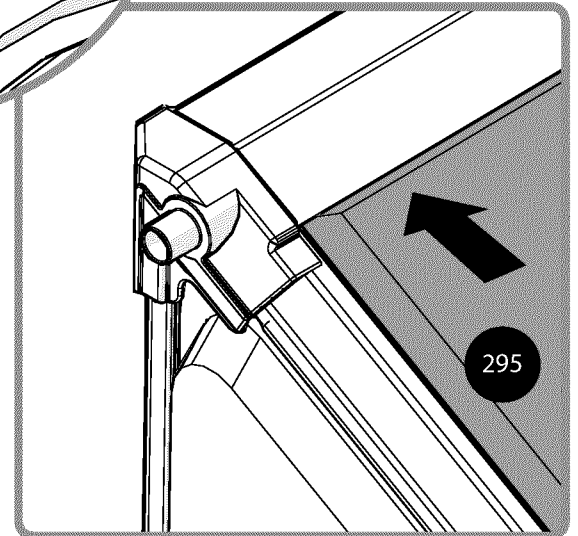
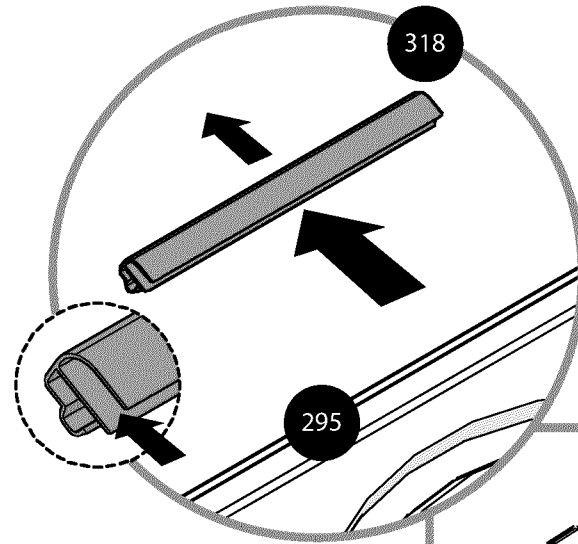
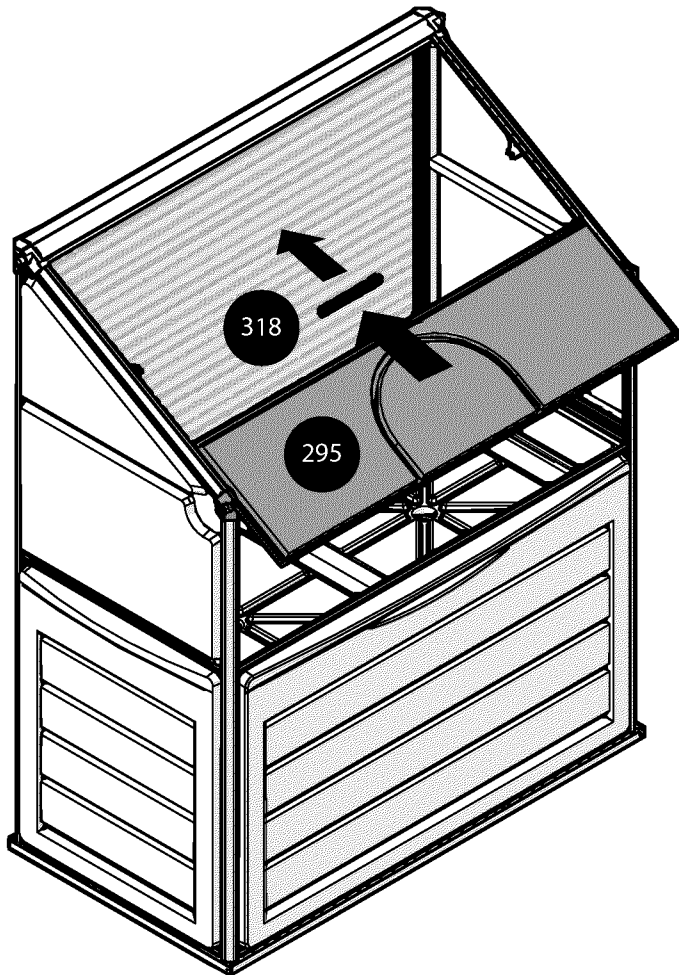



956

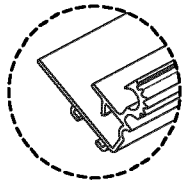
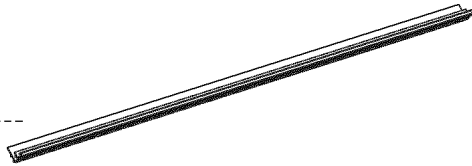

x1

411



x2

412



x2

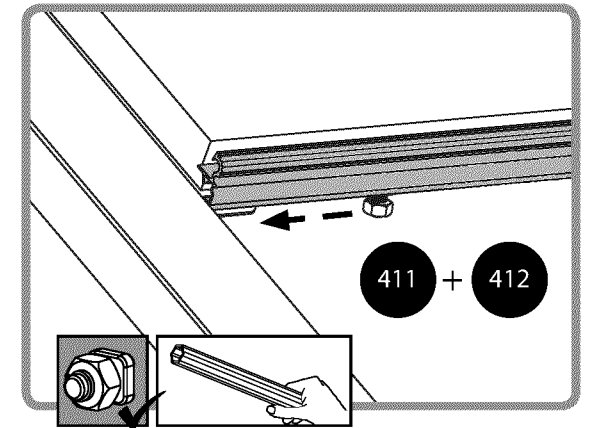
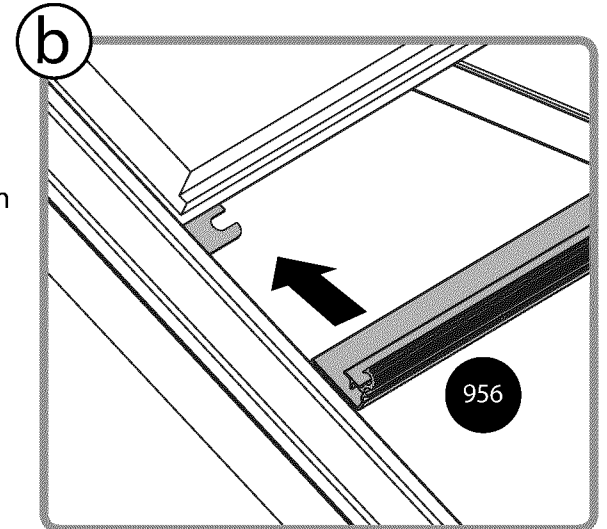
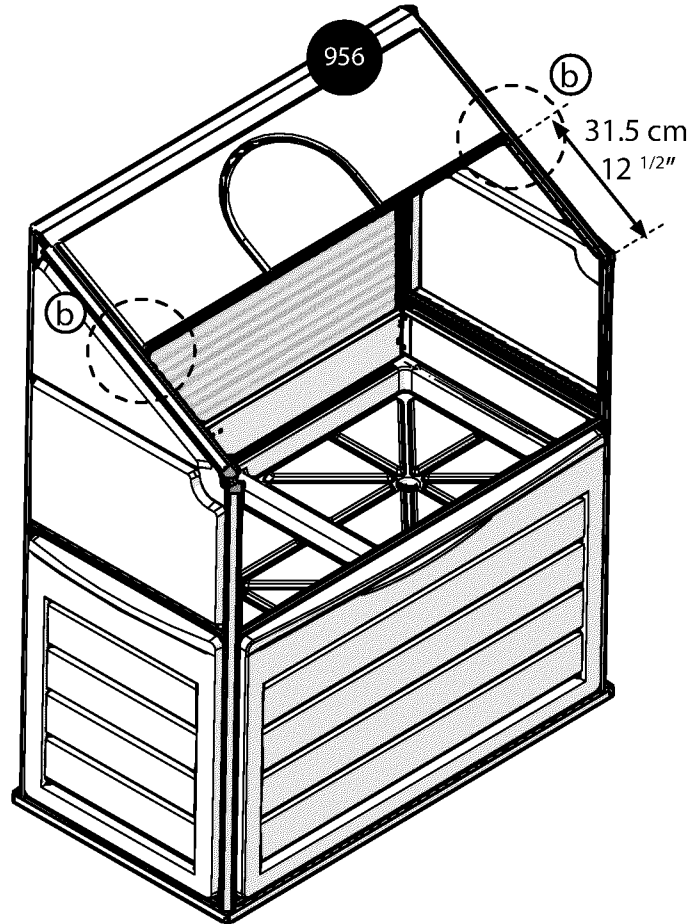
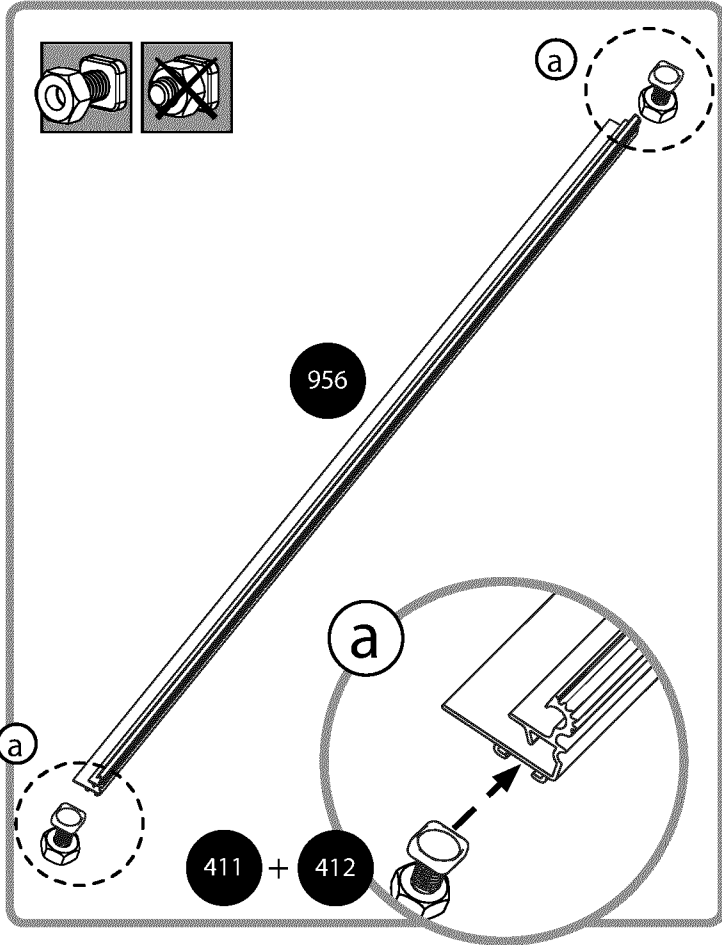



- 131 x2
- 7019 x2
- 411 x4
- 412 x4
- 447 x2

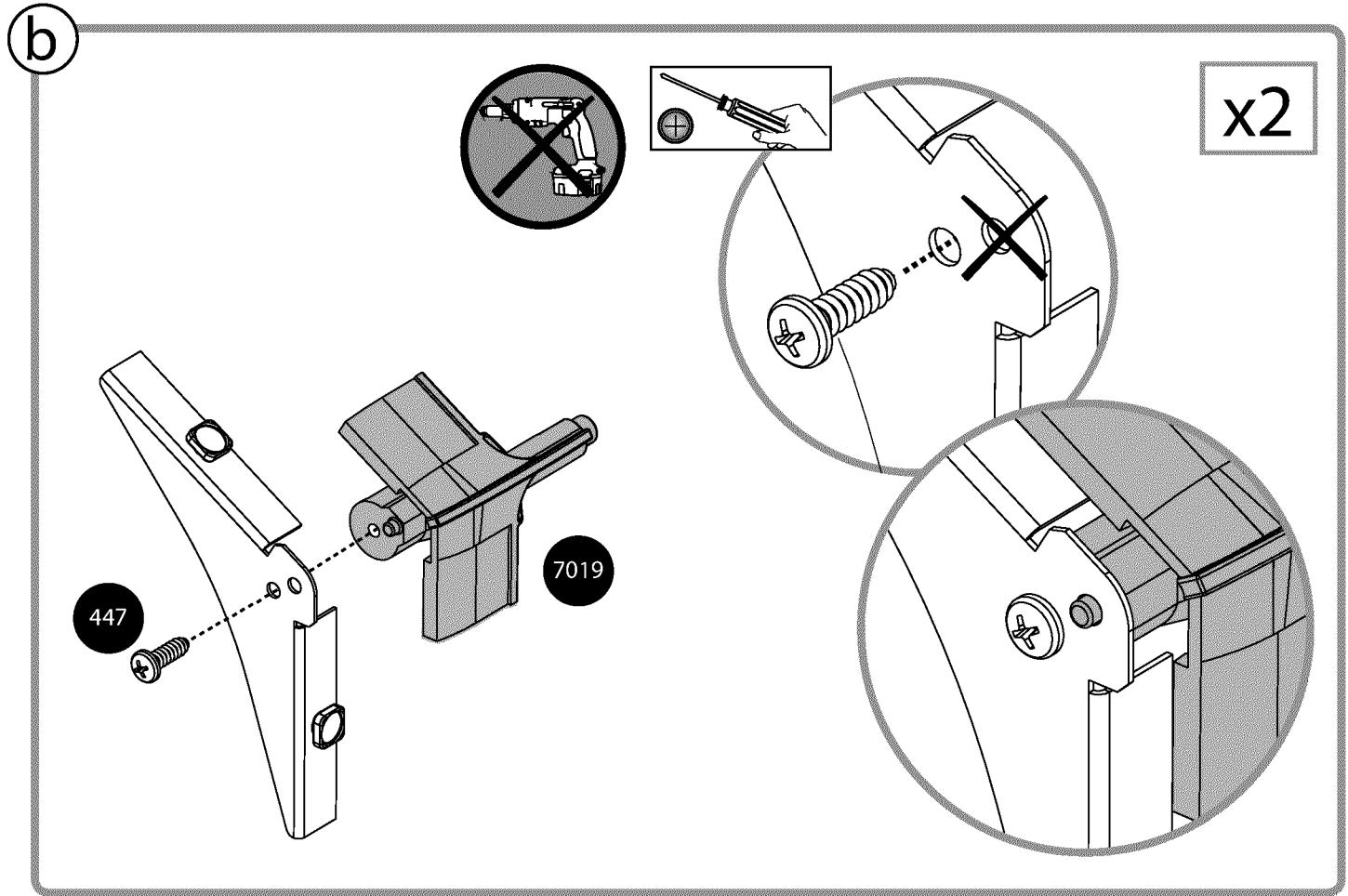
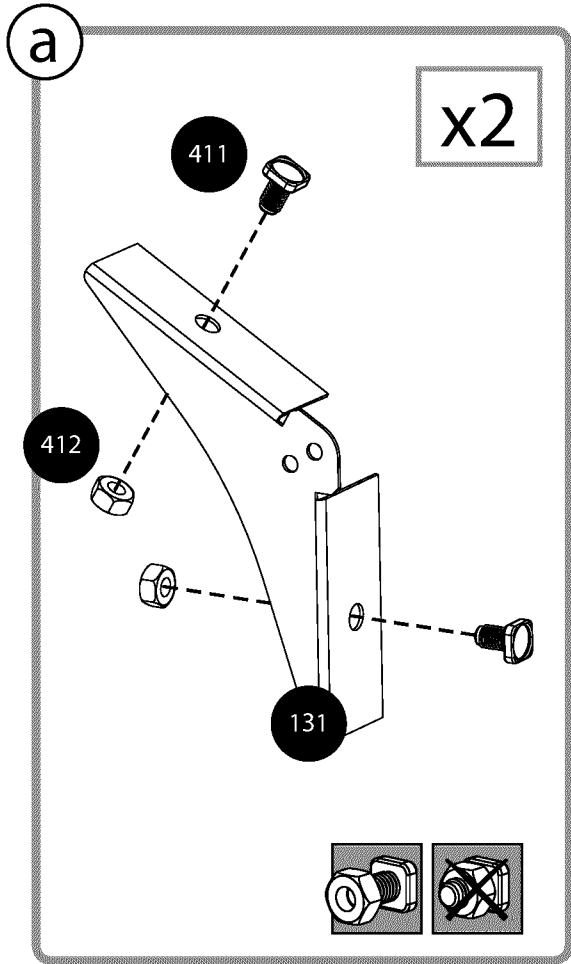



297

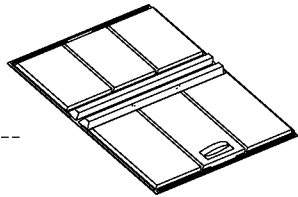

x1

131 + 7019

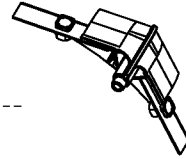

x1

a

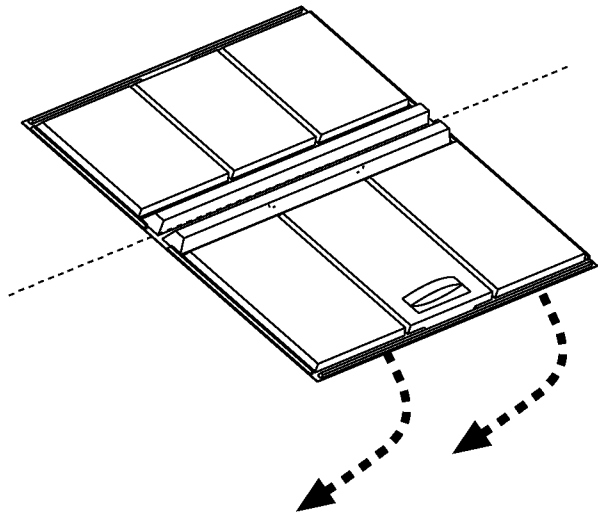

a



b

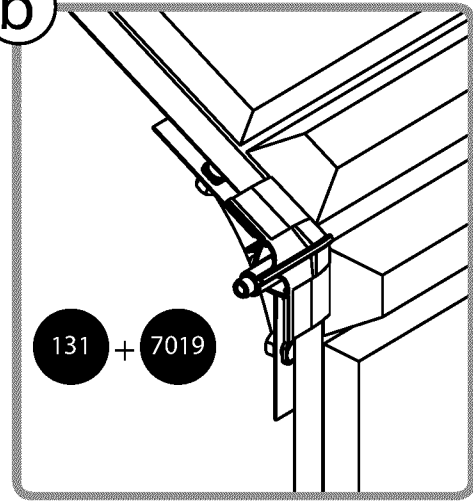

131 + 7019



7017

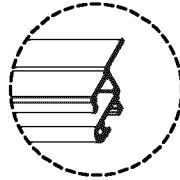
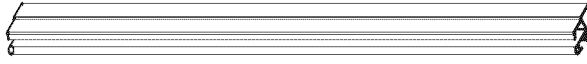

x1

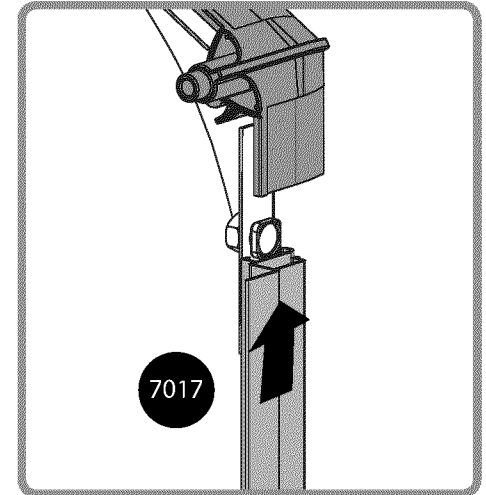
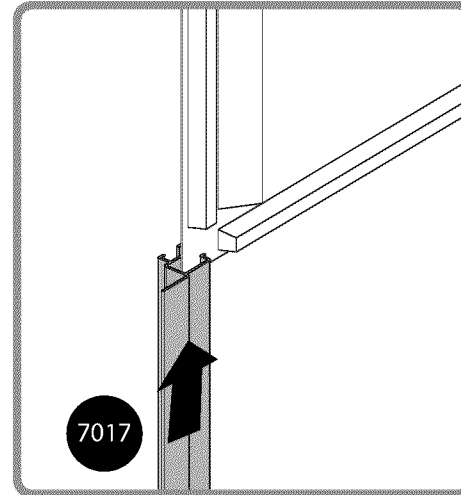
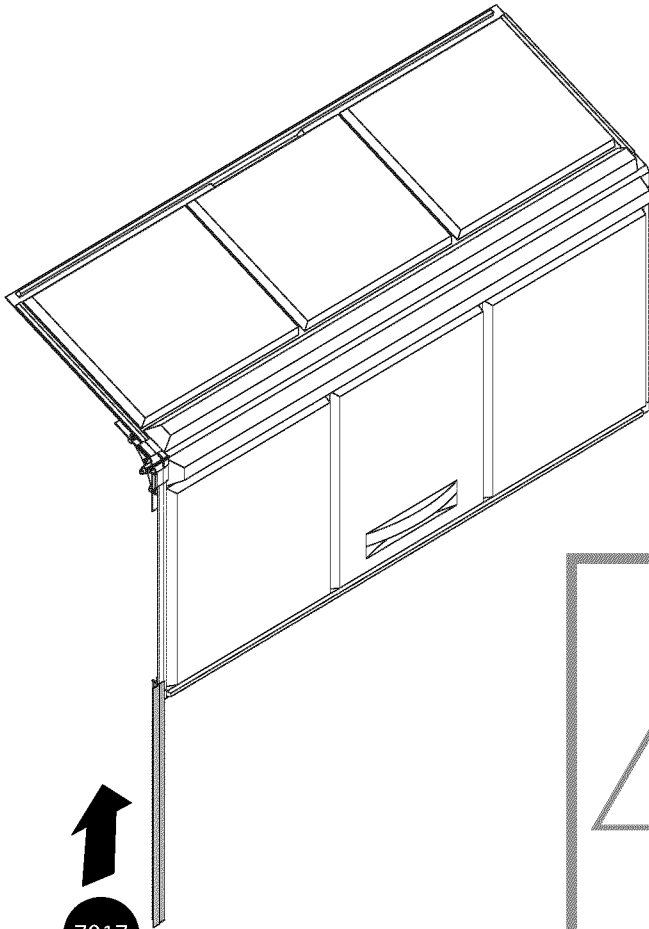

- EN** make sure profiles are inserted all the way till the end into plastic connector.
- D** Stellen Sie sicher, dass die Profile den ganzen Weg bis zum Ende in den Kunststoffanschlüsse eingefügt sind
- FR** Assurez-vous que les profils sont insérés dans le connecteur en plastique sur toute la longueur.

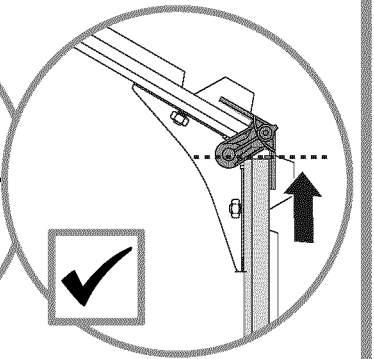
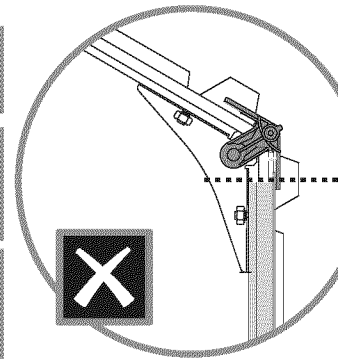



7018

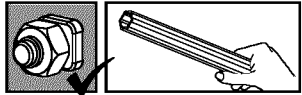
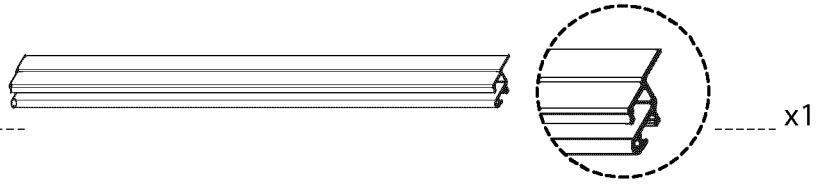

7018

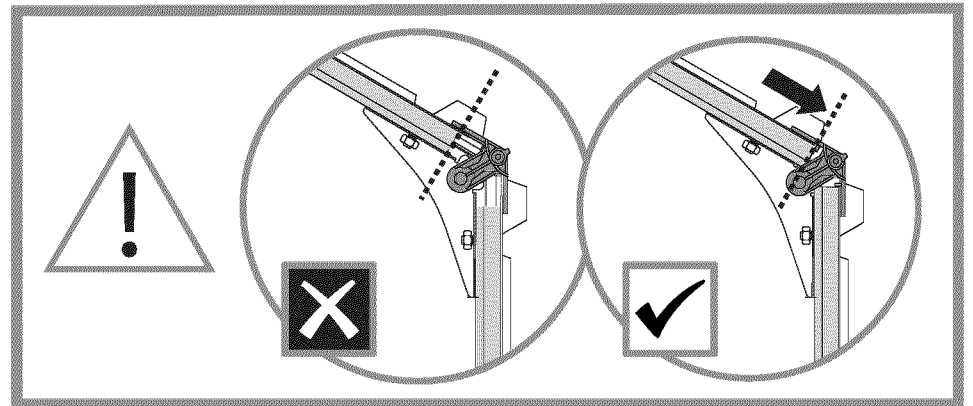
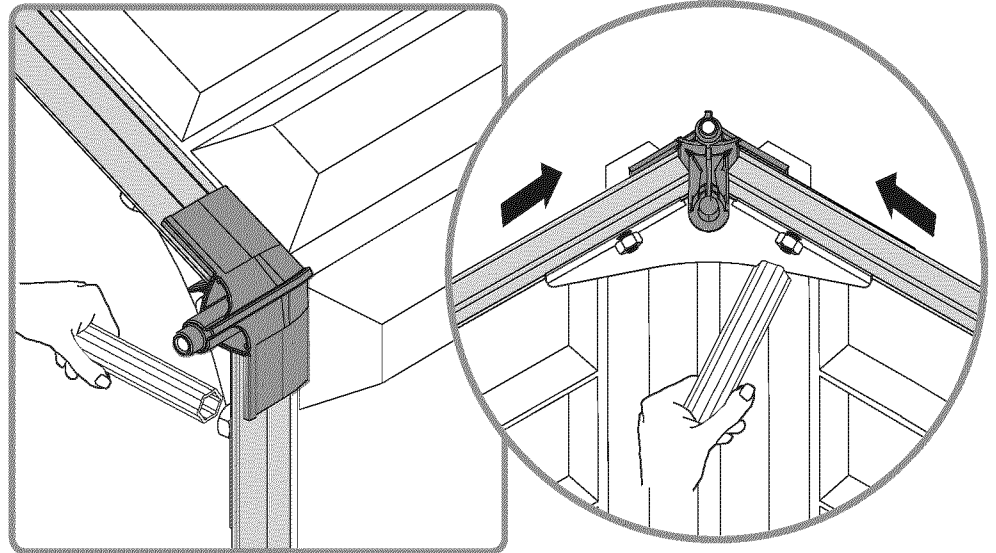
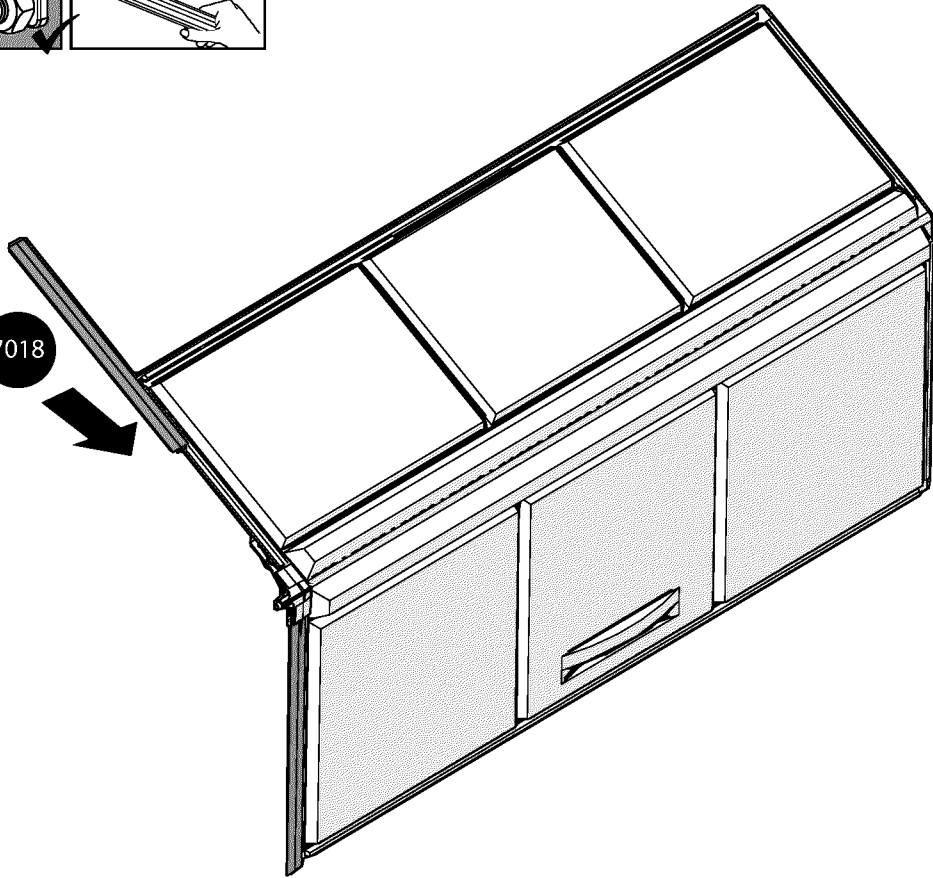

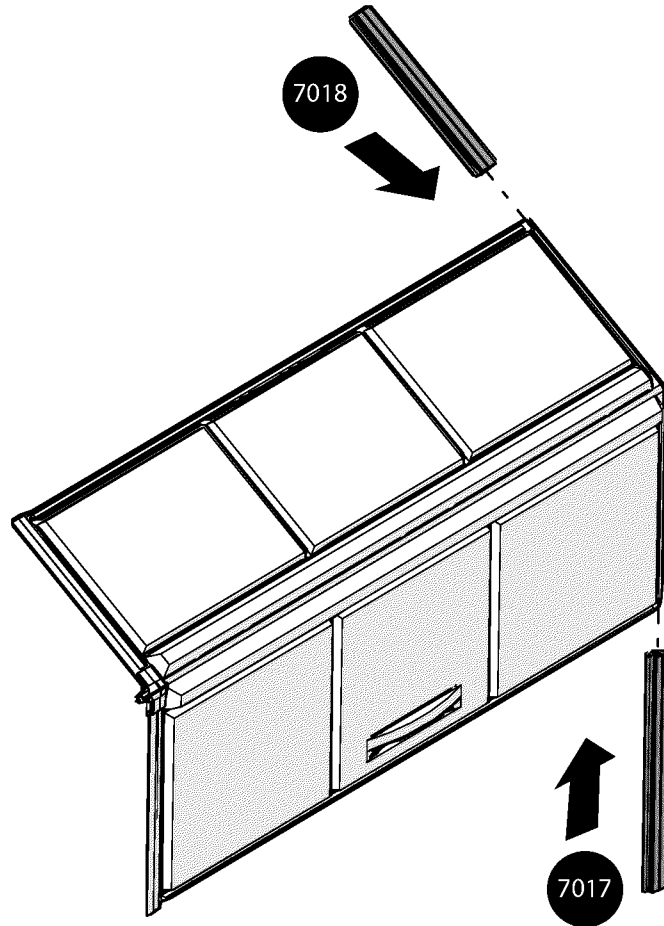
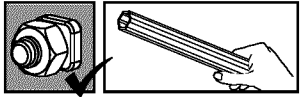
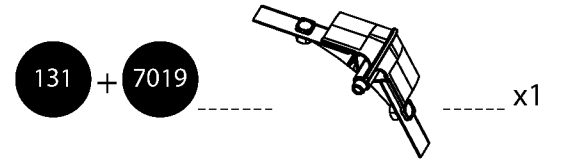
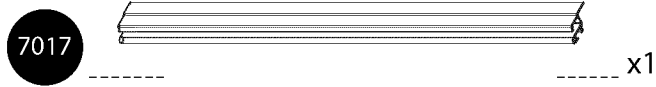

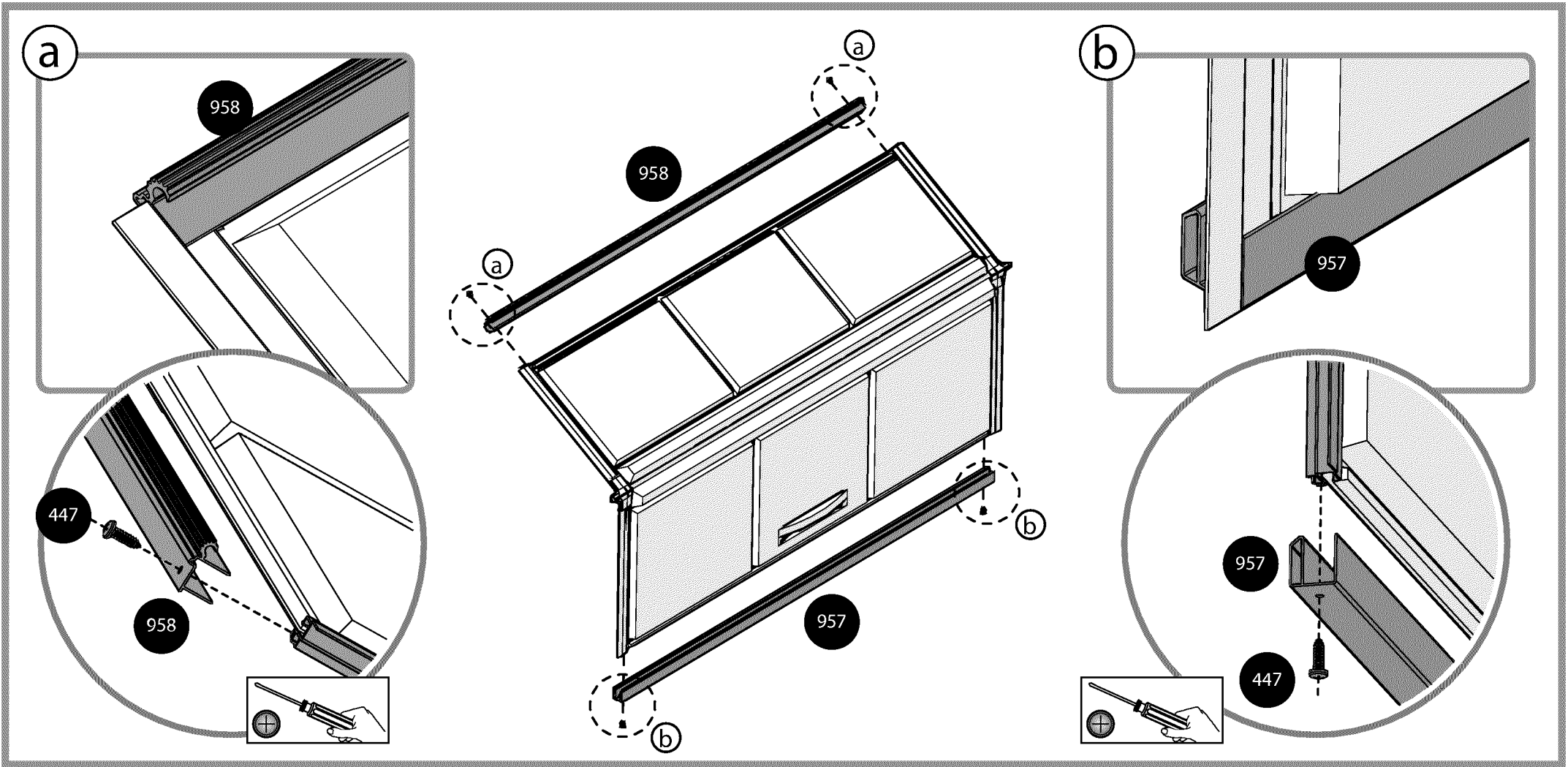
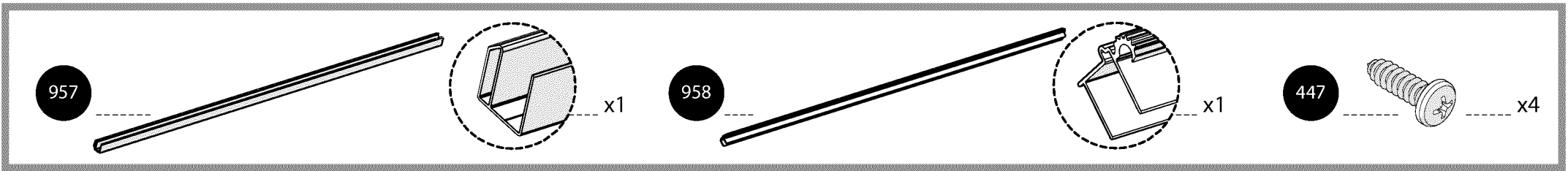



960

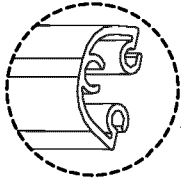

x1



x2

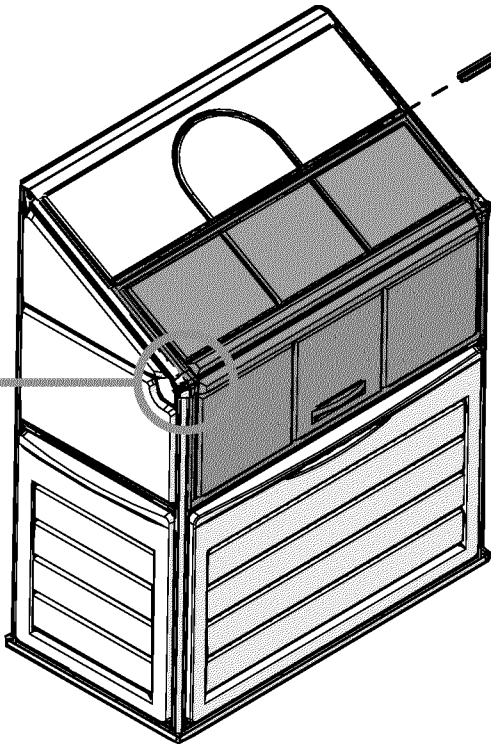

960

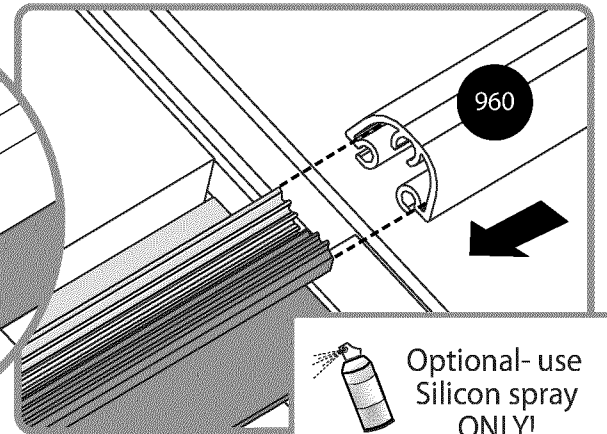
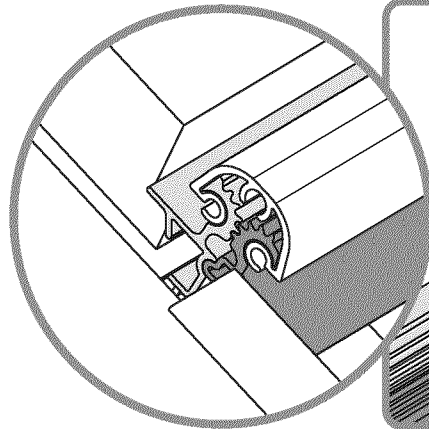
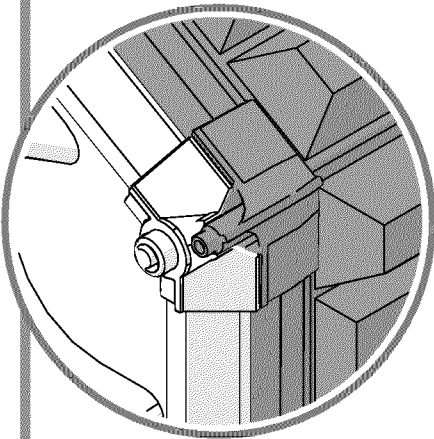
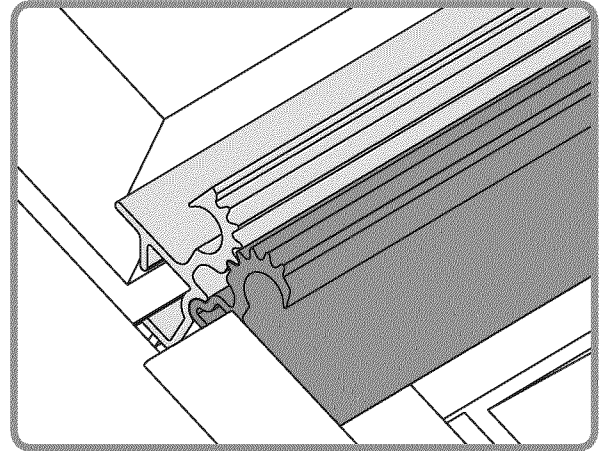

960

Optional- use
Silicon spray
ONLY!

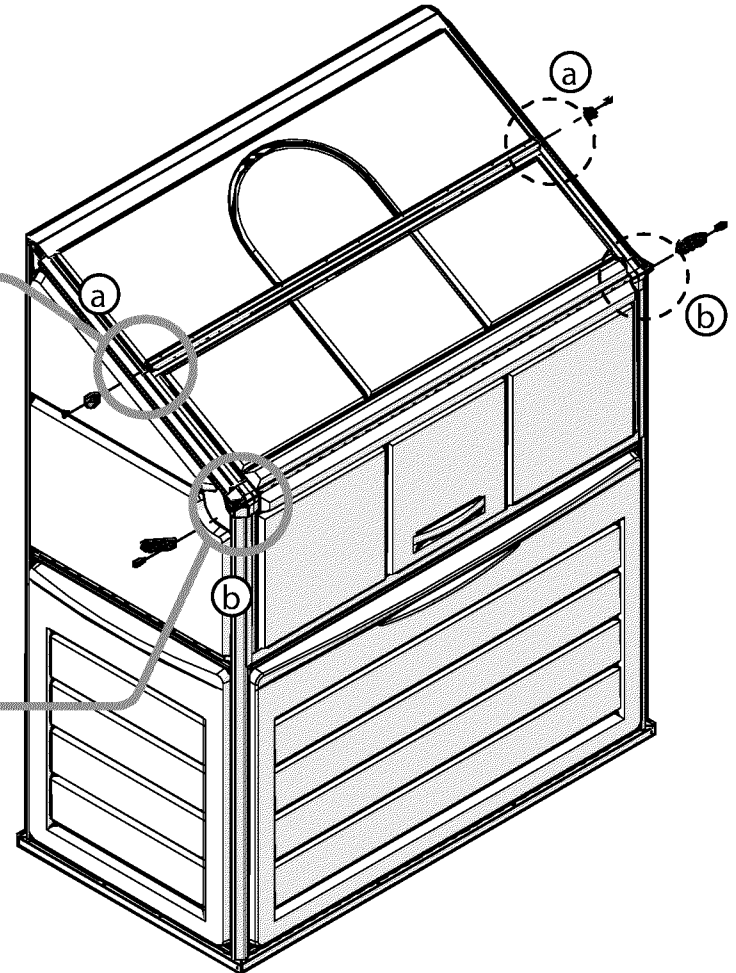
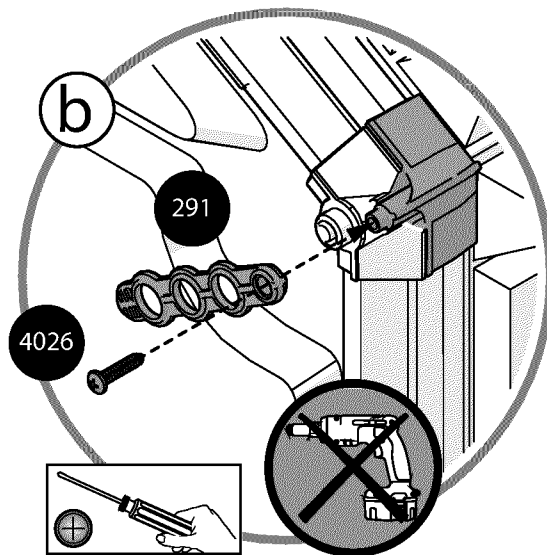
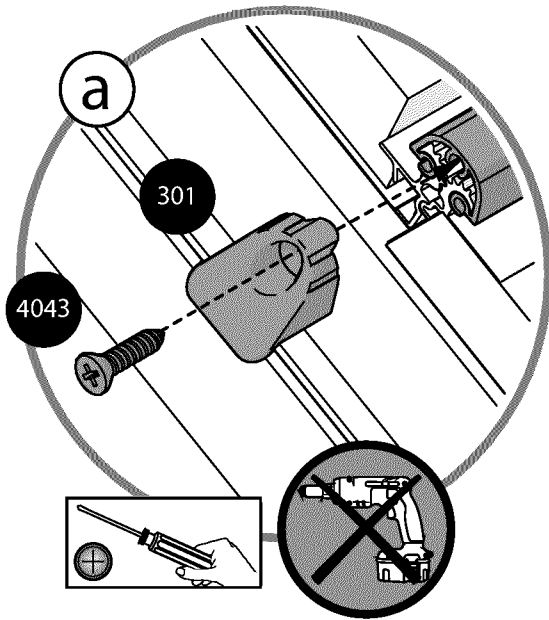
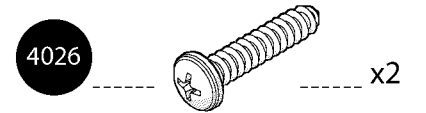
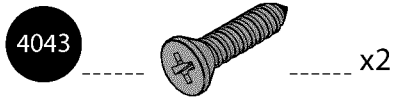
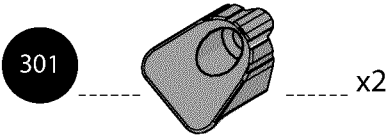

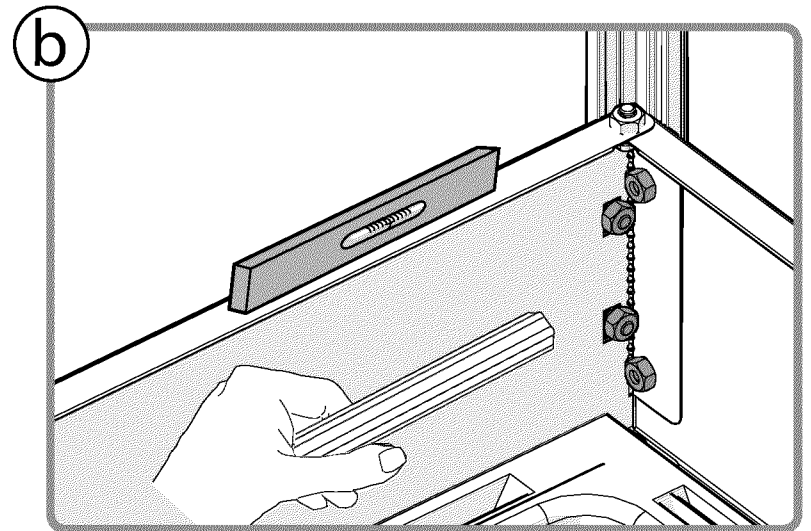
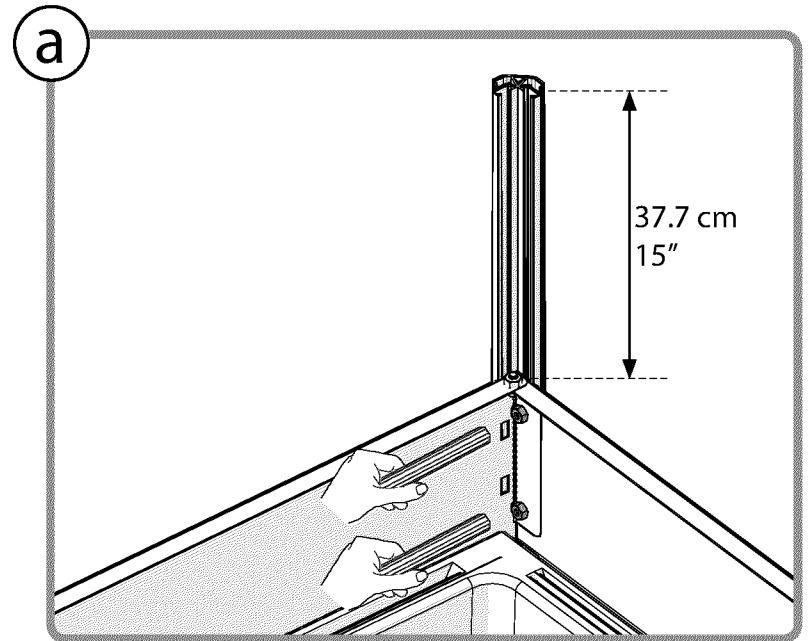
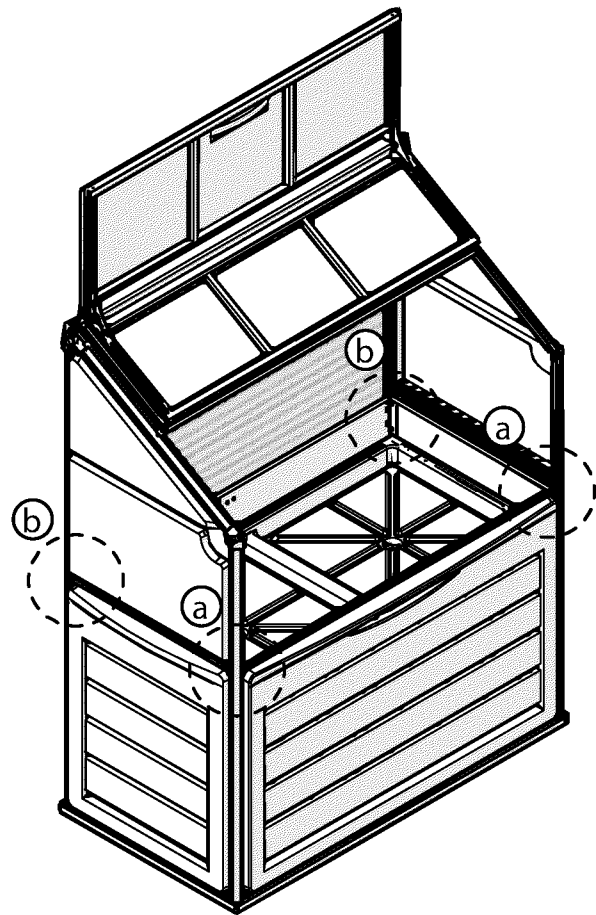
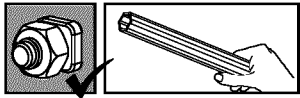
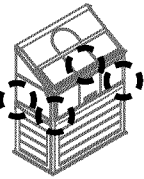

35 Water Draining

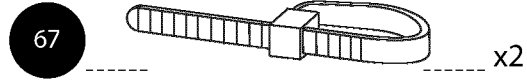

Option A

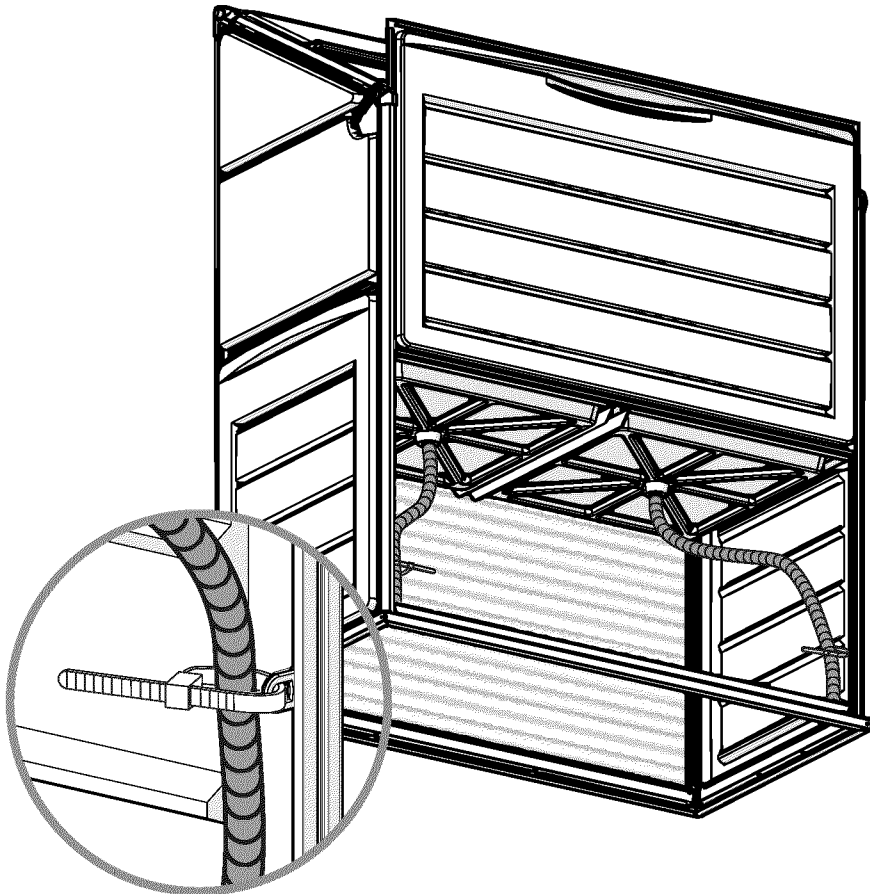

Option B

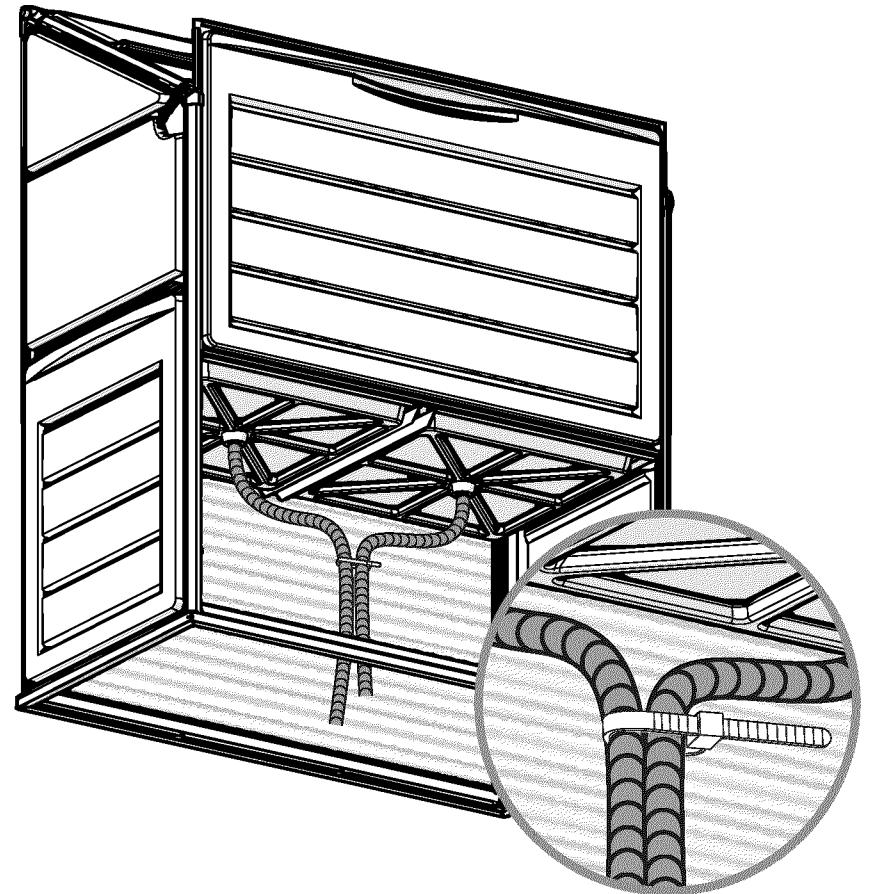

36 Positions

Venilation

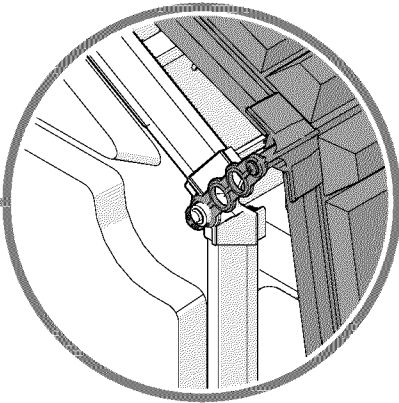
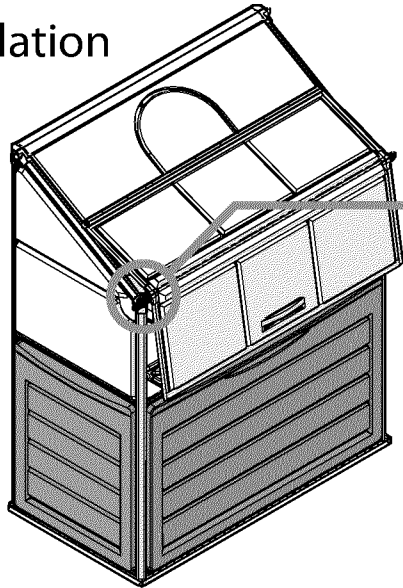

Close

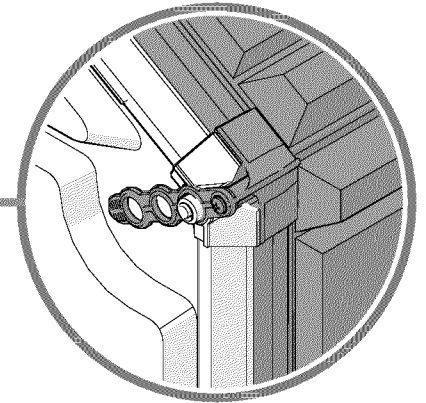
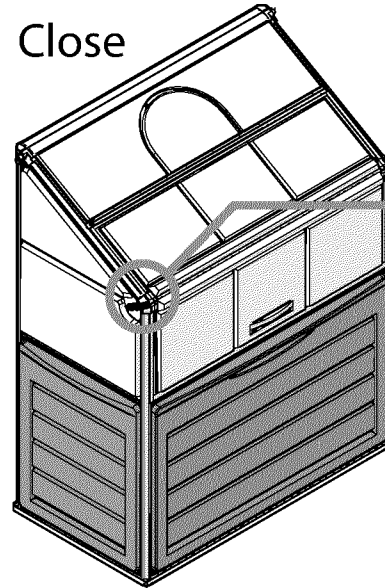

Open

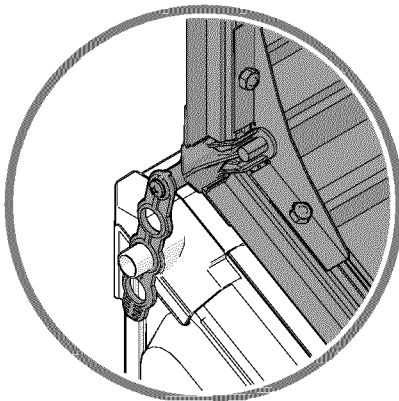
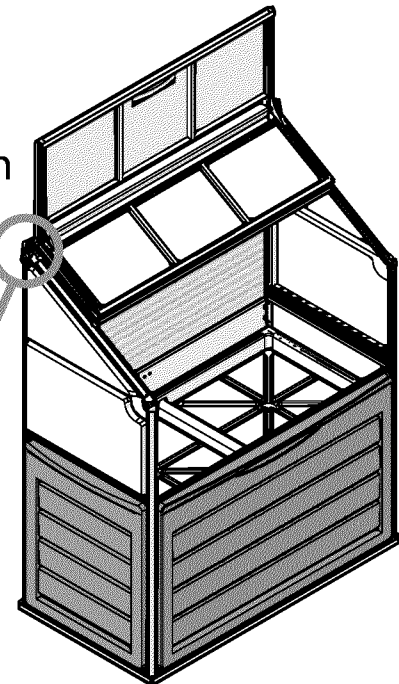

Storage

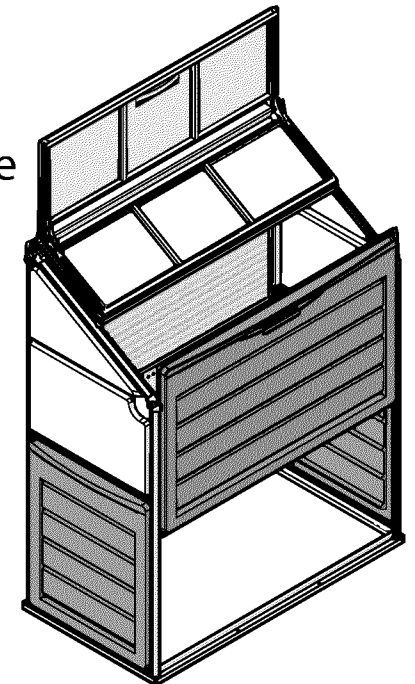

37 Planting & Trellising

