



Assembly Instructions

Automatic Vent Opener

For All PALRAM's Greenhouses

Approx. Dim.

40W x 7L x 5H cm / 15.7"W x 2.7"L x 1.9"L

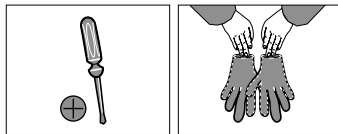
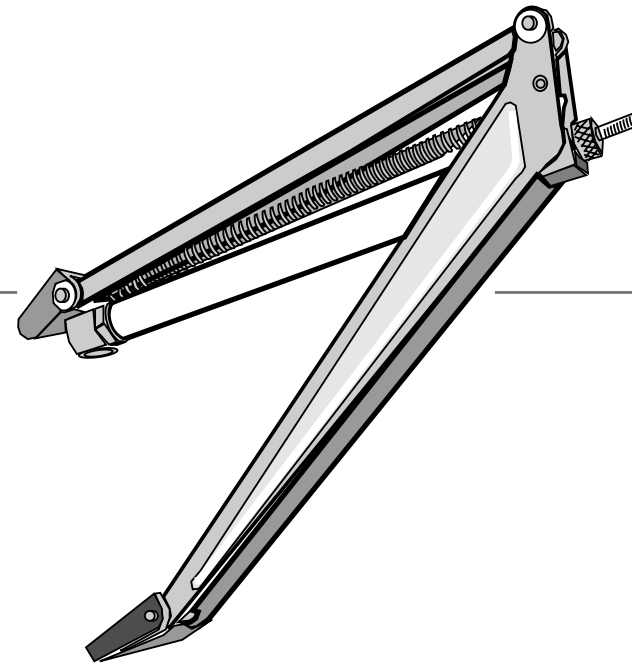

After Sale Service

Email: customer.service@palram.com

USA 877-627-8476
Canada 1 800-866-5749

England 01302-380775
Germany 0180-522-8778

France 0169-791-094
International +972 4-848-6942

www.palramapplications.com

EN

IMPORTANT

- Please CAREFULLY READ ALL notes, instructions & remarks, BEFORE STARTING THE ASSEMBLY of the Automatic Vent Opener.
- CARRY OUT the assembly steps IN THE ORDER SET OUT in the instructions.

» Preparing the unit for fitting

Step 1 - Prior to fitting the Automatic Vent Opener, the power-tube has to be cooled by placing it in a refrigerator for approximately 30 minutes.

Step 2 - Place the cool steel piston rod against a hard surface and push it firmly back into the power-tube.

Step 3 - Lift the Automatic Vent Opener with one hand, and slip the threaded steel piston rod into the plastic-knurled adjuster, which is fixed in the swivelling block.

Step 4 - The plastic-knurled adjuster will be used later to adjust the vent closing position.

» Fitting the unit

- A manual vent opener, if already assembled, should be removed.
- Follow the next steps for fitting the unit according to the greenhouse model you have purchased
- In the last step used the plastic-knurled adjuster to adjust closing gap.

DE

Wichtig

- Bitte lesen Sie alle Notizen, Hinweise und Anmerkungen, bevor Sie mit der Montage des Auto- Fensteröffners beginnen.
- Führen Sie die Montage Schritt per Schritt der Reihenfolge nach, gemäß den Anweisungen durch.

» Vorbereitung des Geräts für den Einbau

Schritt 1 - Vor dem Einbau des Auto- Fensteröffners, müssen Sie die Leistungsröhre in einem Kühlen Kühlschrank für etwa 30 Minuten liegen lassen.

Schritt 2 - Legen Sie die gekühlte Stahlkolbenstange gegen eine harte Oberfläche und drücken Sie sie wieder fest in die Leistungsröhre rein.

Schritt 3 - Heben Sie den Hebel des Auto- Fensteröffners mit der Hand und führen Sie das Gewinde -Stahlkolbenstange in die Kunststoff- Rändelmutter - Einstellvorrichtung, die in dem Schwenkblock befestigt ist, rein.

Schritt 4 - Der Kunststoff- Rändelschraube bzw. Rändelmutter – Einstellvorrichtung wird später zur Verstellung der Luftschließposition verwendet.

» Montage der Einheit

- Falls eine manuelle Entlüftung bereits montiert ist, sollten Sie diese mit dem Auto- Fensteröffner umtauchen.
- Befolgen Sie die nächsten Schritte für die Montage der Einheit je nach dem Gewächshausmodell das Sie gekauft haben
- Im letzten Schritt verwenden Sie bitte die Kunststoff- Rändelschraube Einstellvorrichtung um den Schließspalt anzupassen.

FR

IMPORTANT

- Veuillez LIRE ATTENTIVEMENT TOUTES LES NOTES, consignes et remarques, avant de commencer l'installation de l'Automatic Vent Opener.
- Suivre les étapes d'installation dans l'ordre indiqué dans le mode d'installation.

» Préparation de l'unité avant installation

Étape 1 - Avant d'installer l'Automatic Vent Opener, placer le tube de puissance (power-tube) qui doit avoir été au préalable refroidi. Pour refroidir le tube de puissance, le placer pendant environ trente minutes au réfrigérateur.

Étape 2 - Placer la tige du piston en acier refroidi contre une surface rigide et l'introduire en la poussant fermement dans le tube de puissance.

Étape 3 - Soulever le bras de l'Automatic Vent Opener d'une main puis introduire la tige du piston en acier dans l'ajusteur de plastique fileté, fixé au bloc pivotant.

Étape 4 - La molette en plastique fileté sera utilisé plus tard pour ajuster et fixer l'Automatic Vent Opener en position de fermeture.

» Ajuster l'unité

- Dans le cas où la serre comporte déjà une ouverture de ventilation manuelle, déjà posée, veuillez à la démonter au préalable.
- Suivre les étapes suivantes pour l'installation de l'unité en fonction du modèle de serre que vous avez acquis.
- A la dernière étape, utiliser l'ajusteur en plastique ciselé pour ajuster et bien fixer l'unité.

ES

IMPORTANTE

- Por favor lea todas las notas, instrucciones y comentarios ANTES DE COMENZAR A ARMAR el Automatic Vent Opener.
- LLEVE A CABO el armado EN EL ORDEN ESTABLECIDO en las instrucciones.

» Preparando la unidad para la instalación

Paso 1 - Antes de instalar el Automatic Vent Opener, el tubo de poder debe ser enfriado, para esto ubíquelo en el refrigerador por 30 minutos aproximadamente.

Paso 2 - Ubique la biela de acero enfriada frente a una superficie dura y presiónela firmemente de vuelta al interior del tubo de poder.

Paso 3 - Levante el brazo del Automatic Vent Opener con una mano, y deslice la biela roscada de acero hacia el interior del regulador moleteado en plástico, el que se instala en el bloque rotatorio.

Paso 4 - El regulador moleteado en plástico se usará más adelante para ajustar la posición de cerrado de la ventilación.

» Instalando la unidad

- Si ya existe un abridor de ventilación manual instalado, debe ser removido.
- Siga los pasos para la instalación de la unidad según el modelo de invernadero adquirido.
- En el último paso use el regulador moleteado en plástico para ajustar el espacio de cerrado.

SV

VIKTIGT

- Läs samtliga instruktioner, noteringar och anmärkningar noga innan du börjar montera autoventilen.
- Utför monteringsmomenten i den ordning som instruktionerna föreskriver.

» Förberedelser för montering av enheten

Steg 1 - Innan du monterar automatventilen så skall effektröret kylas. Lägg kolven för kylning i kylskåp ca. 30 minuter.

Steg 2 - Placera den kalla stålkolven mot en hård yta och tryck den ordentligt ner i effektröret.

Steg 3 - Lyft automatventilens arm med ena handen och placera stålkolven in i den plast justeraren som är fixerad i svängtappen.

Steg 4 - Den plast-räfflade justeraren kommer senare att användas för att justera ventilens stängningsposition.

» Montering av enheten

- En manuell öppnare (i fall en sådan finns monterad) ska tas bort.
- Följ sedan nästa steg i monteringen i enlighet med växthusmodellen som du köpt.
- I det sista steget så använd den plast justeringskruven för att justera stängningsluckan.

FI

TÄRKEÄÄ

- LUKEKAA HUOLLELLISESTI KAIKKI lisätiedot, ohjeet ja huomautukset, ENNEN Autoventin kokoonpanoa.
- TOTEUTTAKAA KOKOONPANOVAIHEET ESITETYSSÄ JÄRJESTYKSESSÄ ohjeiden mukaan.

» Valmistautuminen laitteen asennukseen

Vaihe 1 - Ennen Automatic Vent Opener asennusta, teho-putki on jäädytettävä asettamalla se jääkaappiin noin 30 minuutin ajaksi.

Vaihe 2 - Asettaa kylmennetty teräsmäntävarsi kovaa pintaa vastaan ja työntäkää se kunnolla takaisin teho-putkeen.

Vaihe 3 - Nostakaa Automatic Vent Opener käsivarsi yhdellä kädellä ja liuttakaa kierteinen teräsmäntätanko muovi-uritettuun säätimeen, joka on kiinnitetty kääntyvään lohkareeseen.

Vaihe 4 - Muovi-uritettua säädintä käytetään myöhemmin aukon sulkemisasennon säätämiseen.

» Laitteen asentaminen

- Manuaalinen tuuletusaukon avaaja on poistettava jos se on jo asennettu.
- Noudattakaa seuraavia vaiheita laitteen asennuksessa sen mukaan mitä kasvihuonemallia olette ostaneet.
- Käyttäkää muovi-uritettua säädintä raon sulkemisen säätöön viimeisessä vaiheessa.

NO

VIKTIG

- Vennligst les alle notater og instruksjer nøye før montering av Automatic Vent Opener.
- Utfør monteringen i samme rekkefølge som beskrevet i monteringsmanualen.

» Forberedelse av enheten før montering

Steg 1 - Før montering av Automatic Vent Opener på vindu i drivhus, skal enheten kjøles ned ved å ligge i et kjøleskap minst 30 minutter.

Steg 2 - Plasser den kjølige stempelstangen mot en hard flate for så å sette den tilbake inn i kraft-tuben.

Steg 3 - Løft Automatic Vent Opener med en hånd og sett inn ståltråd stempelstangen inn i den plast justerer som er plassert i dreieblokken.

Steg 4 - Den plast-justereren skal senere bli brukt til å justere ventilasjons lukkeposisjon.

» Plassering av enheten i vindusåpning.

- Om en manuell ventilasjonsåpner allerede er montert må denne fjernes.
- Følg de neste steg i forhold til den type drivhus den skal monteres på.
- Siste steg er å tilpasse lukkeåpningen ved å justere med den plast justerer.

Automatic Vent Opener Assembly Instructions for: **Silver Line / Inter Line / Multi Line** Greenhouses

Contents

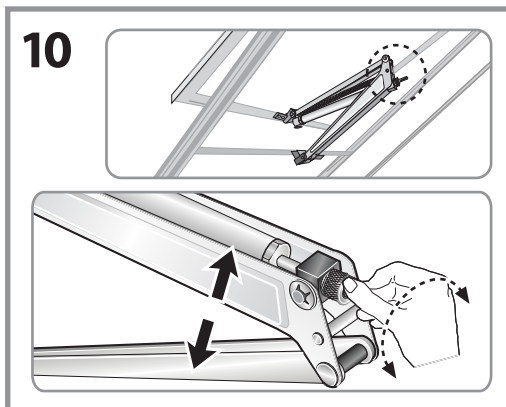
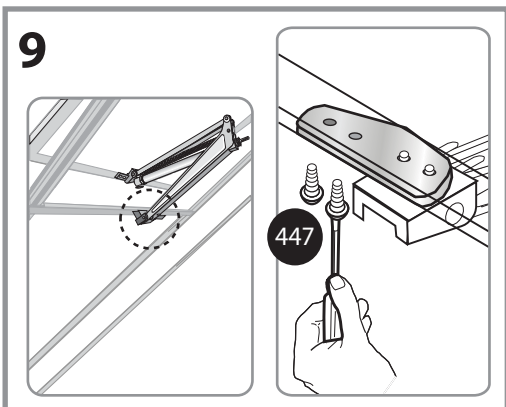
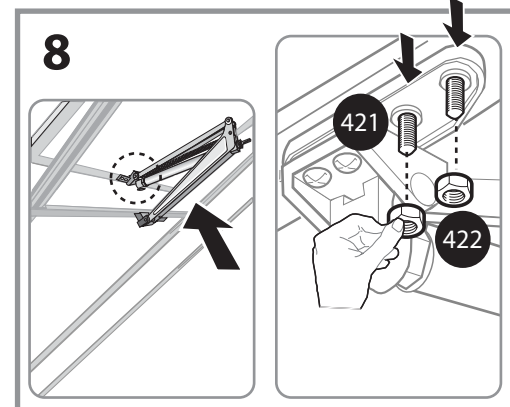
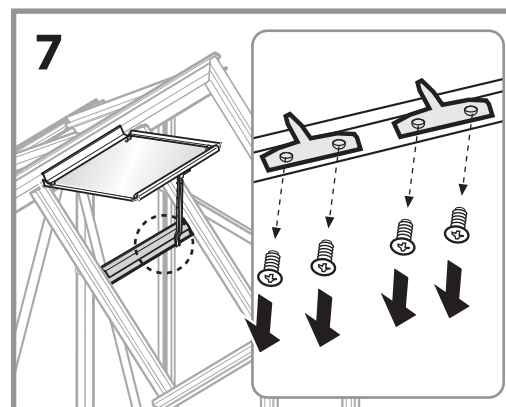
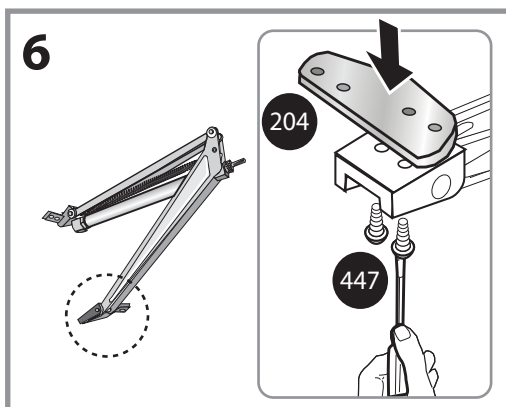
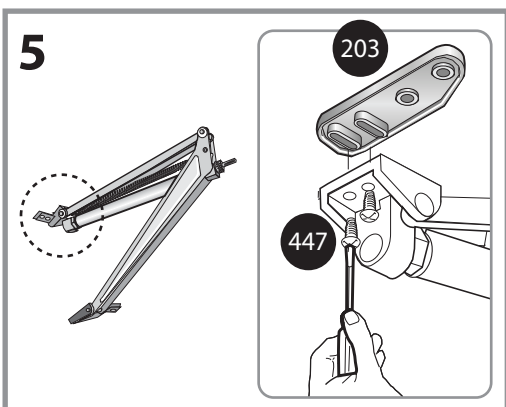
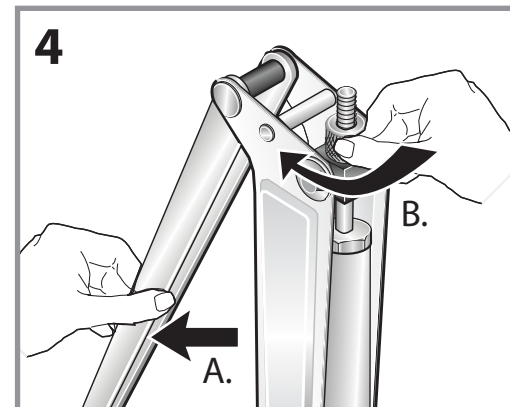
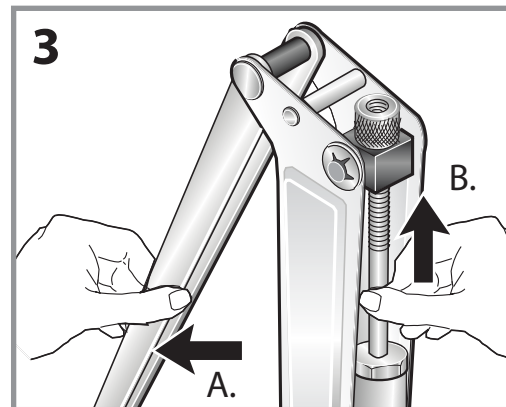
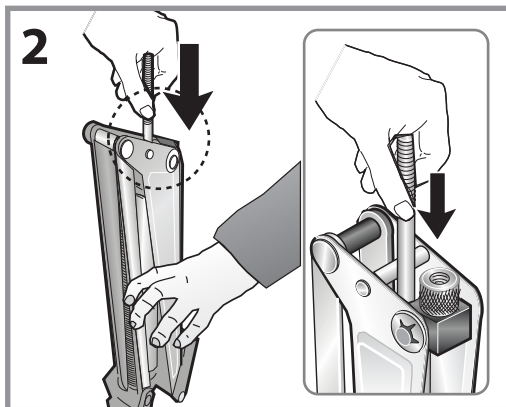
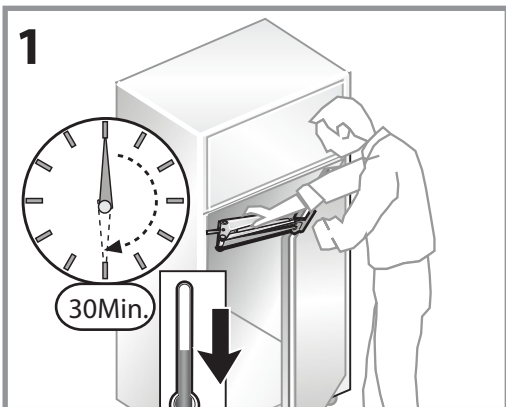
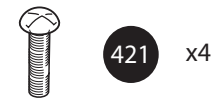
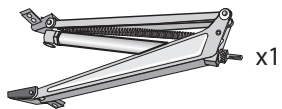

Automatic Vent Opener Assembly Instructions for: **SNAP & GROW** Greenhouses

Contents

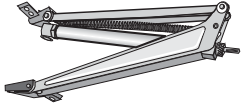

x1



4008 x5

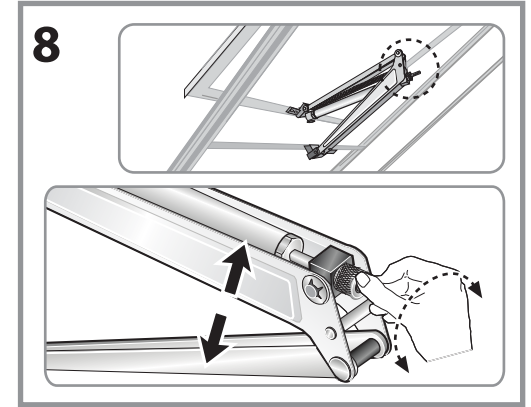
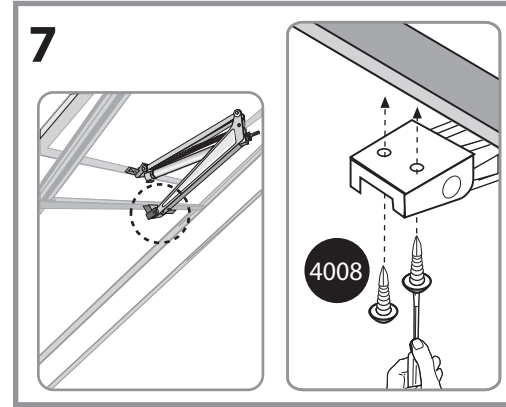
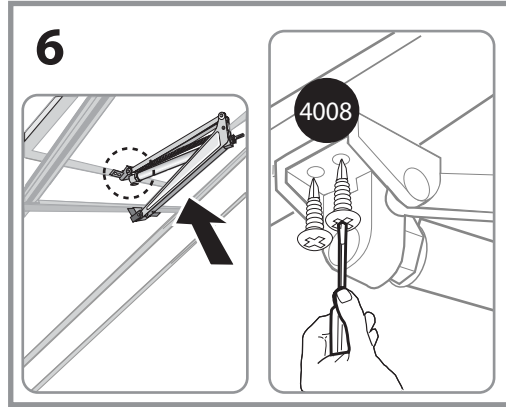
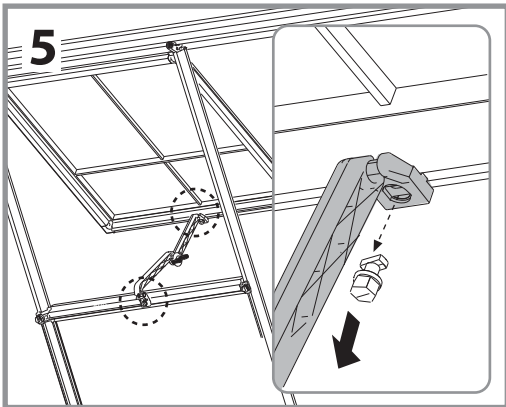
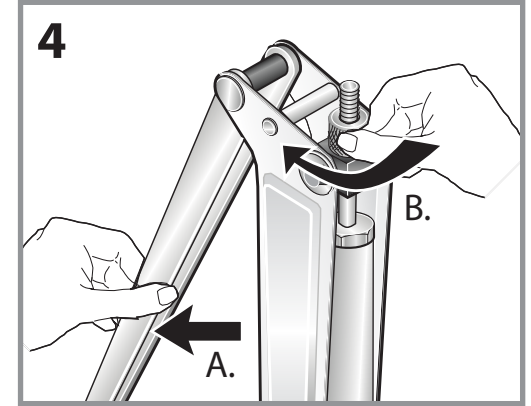
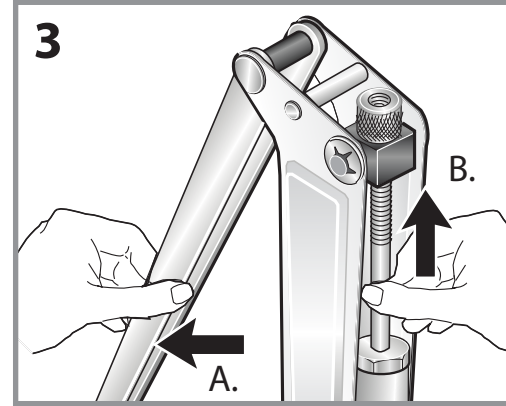
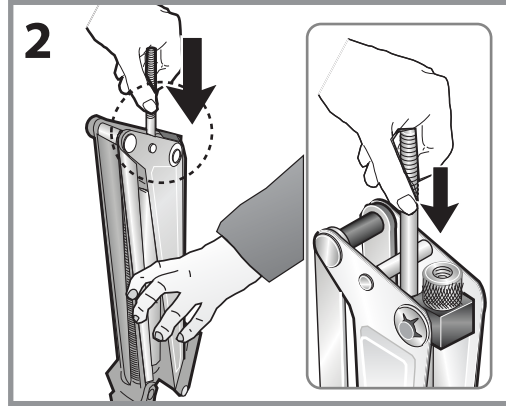
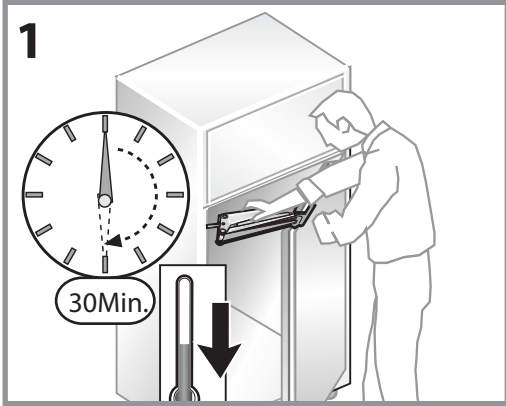

Automatic Vent Opener Assembly Instructions for: **Harmony, Hybrid, Mythos, Octave, Balance, Essence, Americana, Victory** Greenhouses

Contents

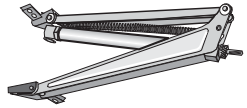

x1



422 x5



465 x5



461 x5



466 x5

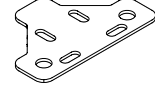

964 x2

